

TRI RAIL FOR C9, M249 & FN MINIMI LIGHT MACHINE GUNS

The Cadex Fore End Rail for the C9, M249 & FN Minimi LMG's provides the gunner a solid mount for lights, aiming lasers, and other weapon accessories. Its construction minimizes heat transferred to the gunner's hand when firing at high rates of fire.

It provides three Mil Std M1913 rails, at 3, 6, and 9 o'clock; the side rail location is optimized to place aiming lasers in the same horizontal plane as the barrel axis for simple zeroing and to keep accessories mounted close to the weapon's center of gravity. This rail system replaces the standard hand guard and clamps securely to the receiver, providing excellent zero retention of attached electro-optics.

A modular design, the rail system features a removable bottom hand guard to permit installation of a vertical grip for greater control at high rates of fire, and if the bipod is used, removal of the bottom rail and hand guard allows the bipod to fold.

This light machine gun rail system is designed and manufactured in Canada, providing operators a high quality rail mount for their mission needs.



Specifications

- Material : Aluminum and composite
- Rail Interface : Mil Std M1913 rails at 3, 6 and 9 o'clock
- Weight : 691 grams / 24.4 ounces
- Colors : Black anodized

Dimension

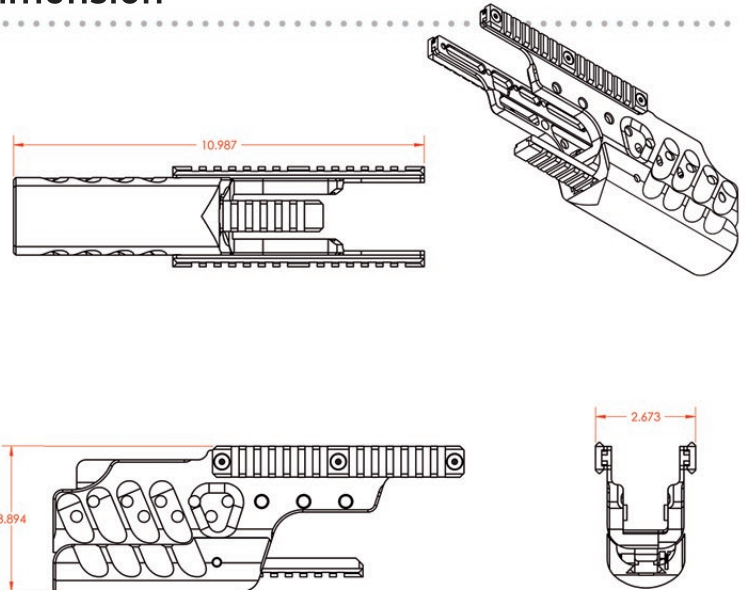

www.cadexdefence.com



CONTACT US FOR MORE INFORMATION

CADEX DEFENCE

755 Ave. Montrichard
St-Jean-sur-Richelieu (Qc)
Canada, J2X 5K8

Tel: 1.450.348.6774 / Fax: 1.450.348.7157

CADEX SALES

Tel: 1.450.348.6774
sales@cadexinc.com
www.cadexdefence.com