

Unitized Scope Ring

Cadex's Unitized Scope Ring provides a rock solid mount for sniper optics, with multiple applications for flat top AR's and bolt action rifles. These rings are CNC machined for precise alignment of the front and rear scope bearing surfaces and all edges are smoothed to protect the shooter. The ring caps are accurately aligned to the ring body to hold the scope in the mount in correct alignment. The rings incorporate a high grade steel cross lug and nut to secure the ring to the weapon rail and the dovetail is machined to fit all Mil Specification M1913 Picatinny rails, ensuring the scope is secured with no twisting of the optical tube assembly and no shifting under recoil.

Coupled with the precision fit of the scope ring caps, high grade hardware is used to clamp the scope to ensure the scope caps will bear evenly, making sure that your scope will be centered.

Customers may request different ring diameters and heights to fill their particular requirements. These rings are made of high grade aluminum alloy with a hard anodized finish for durability. Designed and manufactured in Canada, the Cadex Unitized Scope Ring provides an excellent scope mounting solution.

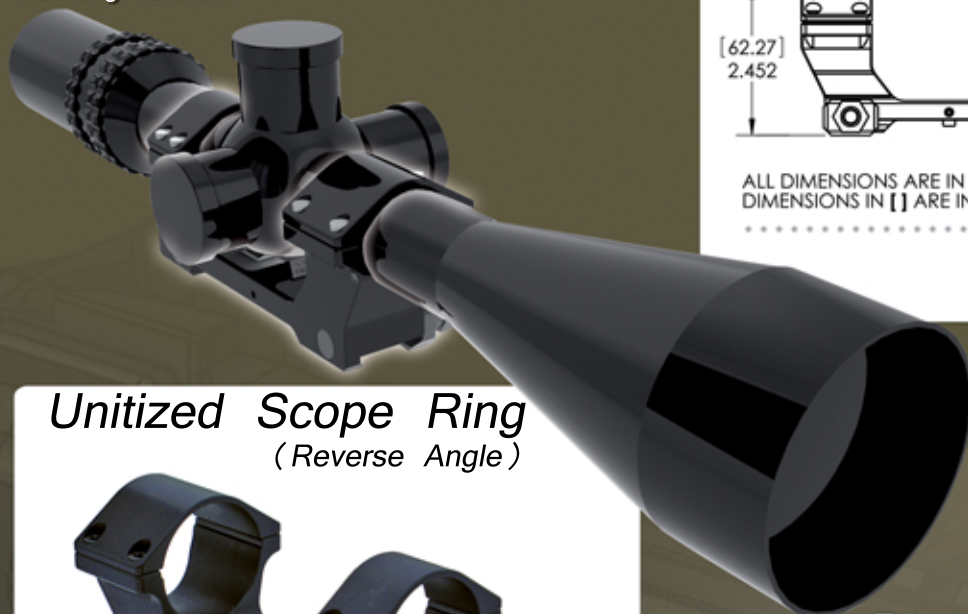

Unitized Scope Ring (Reverse Angle)



Titanium



Specifications

Material & finish	: Aluminum & Titanium, black anodized
Weight	: 195 grams / 6.88 ounces
Scope diameter	: 34mm, others available on request
Scope mounting angle	: 0 MOA, others available on request

Dimension

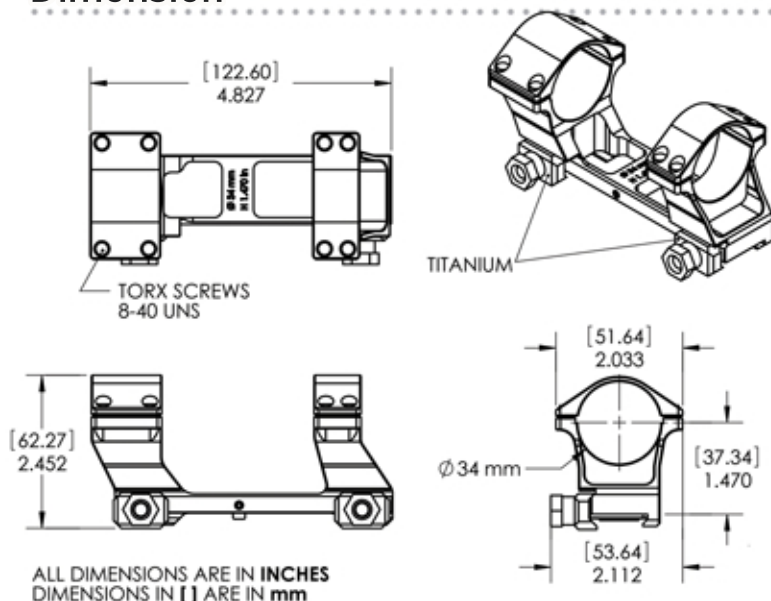

www.cadexdefence.com



CONTACT US FOR MORE INFORMATION

CADEX DEFENCE

755 Ave. Montrichard
St-Jean-sur-Richelieu (Qc)
Canada, J2X 5K8

Tel: 1.450.348.6774 / Fax: 1.450.348.7157

CADEX SALES

Tel: 1.450.348.6774
sales@cadexinc.com
www.cadexdefence.com