

PRECISION RIFLE
USER MANUAL

CEEDX

30/300/33

CAEDEX
DEFENCE 



Important usage information for:

Rev. 2.3 - 20220124

CDX PRECISION RIFLE

If you have any remark about your new Cadex firearm, please contact us:

Cadex Inc.
755 avenue Montrichard, Saint-Jean-sur-Richelieu
Quebec, Canada J2X 5K8
Phone: 450-348-6774
www.cadexdefence.com

Please use the following spaces to record information about your new firearm.

Model: _____

Serial number: _____

Bought from: _____

Purchase date: _____

Thank you for choosing a Cadex CDX Precision Rifle

Congratulations on your purchase of a Cadex CDX Precision Rifle. The CDX Precision Rifle is one of the most accurate, sophisticated and most finely constructed bolt-action rifles available today. The CDX Precision Rifle represents a new generation of bolt-action rifles, designed with improved features for superior performance. With proper care, your CDX Precision Rifle will give you many years of dependable, enjoyable service.

YOU ARE RESPONSIBLE FOR FIREARM SAFETY

Failure to heed any of the following warnings could result in serious injury or death. As a gun owner, you accept a set of demanding responsibilities. How seriously you take these responsibilities can be the difference between life and death. There is no excuse for careless or abusive handling of any firearm. At all times handle this firearm, and all other firearms, with intense respect for their power and potential danger. Please read and understand all of the cautions, warnings, notices, proper handling procedures and instructions outlined in this user manual before using your new chassis.

For best results, we recommend that you use match grade ammunition. Your firearm was factory tested using match grade ammunition to insure that your rifle met our stringent quality control.

This document contains information that is proprietary to Cadex Inc. Neither this document nor the information contained herein shall be used, duplicated or communicated by any means to any third party, in whole or in part, except with the prior written consent of Cadex Inc. This restrictive legend shall not be altered or obliterated from this document.

Contents (1/2)

1.	THE ELEVEN RULES OF FIREARM SAFETY	7
1.1.	Always keep the muzzle of your firearm pointed in a safe direction even though you are certain it is unloaded	7
1.2.	Firearms should be unloaded when not actually in use.....	7
1.3.	Never rely on your firearm's safety	8
1.4.	Use proper ammunition	8
1.5.	Learn the mechanics and handling characteristics of your firearm	10
1.6.	Always wear eye and ear protection when shooting	10
1.7.	Be sure the barrel is clear of obstructions before shooting	11
1.8.	Be sure of your target and what's beyond it	11
1.9.	If your rifle fails to fire when the trigger is pulled, handle with care	11
1.10.	Never alter or modify your firearm and have it serviced regularly	12
1.11.	Teach and supervise firearms safety to all members of your family	12
2.	CDX PRECISION RIFLE FEATURES	14
2.1.	LITE configuration	14
2.2.	TAC configuration	16
2.3.	Caliber designation.....	17
3.	IMPORTANT PARTS OF THE FIREARM	18
3.1.	The safety mechanism	18
3.2.	The locking system.....	19
3.3.	The bolt assembly	19
A.	To install bolt assembly.....	19
B.	To remove bolt assembly.....	19
C.	Disassembling the bolt assembly	20
D.	Removing the firing pin assembly.....	20
E.	Reassembling the firing pin assembly	20
3.4.	The Trigger Assembly.....	21
A.	Trigger pull weight adjustment.....	21
B.	Trigger lever position adjustment	22
C.	Single stage vs double stage conversion	23
D.	Trigger cleaning and maintenance	23
3.5.	The barrel	24
A.	New firearm break-in procedure	24
B.	To check the inside of the barrel.....	24
C.	To remove object from inside the barrel	24
D.	To clean the barrel	24
3.6.	The muzzle brake	25
3.7.	Chassis description	25
3.8.	Operation of stock controls (LITE configuration)	26

Contents (2/2)

A.	Adjusting length of pull	26
B.	Adjusting the length of pull locking mechanism.....	26
C.	Adjusting height of cheek piece.....	27
D.	Adjusting the height of recoil pad	27
E.	Folding, extending and tightening the butt stock	28
3.9.	Operation of stock controls (TAC configuration).....	29
A.	Adjusting the length of pull	29
B.	Adjusting the height of cheek piece.....	30
C.	Adjusting the height of recoil pad	30
3.10.	Disassembly of the firearm	31
A.	Top rail and fore-end tube disassembly.....	31
B.	Removal of detachable base and magazine sleeve (if equipped).....	32
C.	Removal of action from the chassis.....	33
3.11.	Assembly of the firearm.....	34
A.	Installation of the action into the chassis	34
B.	Installation of detachable base and magazine sleeve (if equipped).....	35
C.	Installation of top rail and fore-end tube	36
4.	LOADING / UNLOADING OF THE FIREARM	37
4.1.	Loading.....	37
4.2.	Unloading	37
5.	CLEANING AND MAINTENANCE	38
5.1.	Lubrication	38
5.2.	Barrel cleaning.....	38
5.3.	Receiver and trigger assembly cleaning.....	38
5.4.	Bolt assembly cleaning.....	39
5.5.	Chassis cleaning and maintenance.....	40
5.6.	Threadlocker application procedure	40
6.	TECHNICAL AND WARRANTY SUPPORT	40
7.	APPENDIX A - SPARE PARTS	42
7.1.	Firearm spare parts	42
7.2.	Chassis spare parts - LITE configuration	43
7.3.	Chassis spare parts - TAC configuration	46
8.	APPENDIX B - RECOMMENDED TORQUE SETTING	48

YOU ARE RESPONSIBLE FOR FIREARM SAFETY!

Failure to heed any of the following warnings could result in serious injury or death. As a firearms owner, you accept a set of demanding responsibilities.

How seriously you take these responsibilities can mean the difference between life and death. There is no excuse for careless or abusive handling of any firearm.

Always handle this firearm, and all other firearms, with extreme care and caution.

Please read and understand all of the cautions, warnings, notices, proper handling procedures and instructions outlined in this user manual before using your new firearm.

Once fired, a bullet cannot be brought back. It is critical that you understand and apply safe firearm handling and storage practices at all times, including during the unpacking of your new Cadex rifle.

WARNING!



Any complete disassembly or modification of the chassis butt stock internals and folding stock mechanism by the customer will void the warranty.

Any modifications and/or disassembly of the firearm and/or chassis other than those described in this manual will void the warranty.

This Cadex firearm, chassis and all components have been installed and fine tuned to its optimum fit and finish by a factory certified Cadex firearms technician.

If you experience any problem with your chassis and/or firearm other than standard care and maintenance practices please contact our customer service immediately at 1-450-348-6774.

1. THE ELEVEN RULES OF FIREARM SAFETY

1.1. Always keep the muzzle of your firearm pointed in a safe direction even though you are certain it is unloaded

This is the most important firearm safety rule. A safe direction is one in which an accidental discharge will not cause injury to yourself or others. Never allow your firearm to point at anything you don't intend to shoot. Be especially careful when you're loading or unloading. Treat every rifle as if it were loaded. And make it a habit to know where the muzzle is pointed at all times, even when your firearm is unloaded. No one will be injured by an accidental discharge if you keep your firearm pointed in a safe direction. Be extremely alert and aware of all persons and property within the range of your ammunition.

1.2. Firearms should be unloaded when not actually in use

Load your firearm only when you're in the field or on the target range and ready to fire. Never let a loaded firearms out of your sight or out of your hands. Unload it as soon as you're finished shooting. Always unload the firearm before you bring it into your car, camp or home. Remember, unloading your firearm means unloading it completely, so there is no ammunition in the chamber or in the magazine. Before handling a firearm or passing it to someone else, visually check the chamber, receiver and magazine to be certain they do not contain ammunition and leave the action opened. Always keep the rifle's action open when not in use. Never assume a firearm is unloaded even if you were the last person to use it. Always check for yourself. Do not dry fire the firearm on an empty chamber; the chamber may not be empty! Treat every firearm as if it were loaded. Always double check that the chamber and magazine are clear and empty of all ammunition.

Let common sense rule when carrying a loaded firearm. If you're in a situation that could risk accidental discharge – such as crossing a fence, wading through a stream or climbing a tree – always unload your rifle. Never pull or push a loaded firearm toward yourself or another person. Never carry a loaded firearm in a scabbard, detached holster or gun case. Certain firearms are equipped with internal security devices to prevent unauthorized use. In addition, some firearms owners use external devices, such as cable locks and trigger blocks, for the same purpose. Even if you use such a device, you should still keep your firearm unloaded when stored or not in use. Using internal or external devices cannot substitute, however, for securing your firearms and ammunition in a separate, locked location. Always respect local Firearms Storage Laws and legislation.

Safe storage of firearms is just as critical as safe handling. Never store firearms loaded. Be sure to keep your firearms in a secure place where unauthorized persons cannot get their hands on them without your knowledge.

Take special care if there are children around. Store your firearm and ammunition separately, well beyond the reach of children. Take prudent safeguards to ensure your firearm does not become available to untrained, inexperienced or unwelcome hands. Children are fascinated by firearms. It's a natural curiosity that can have tragic consequences when not properly supervised. Store all firearms in a secure, locked case or gun safe. Keep your firearm unloaded when not in use.

1.3. Never rely on your firearm's safety

Treat every firearm as if it can fire at any time, whether or not there's pressure on the trigger. Your firearm has been carefully designed to maximize performance and safety; however, because a rifle's safety is a mechanical device, it could fail. Never rely on your firearm's safety because it can be jammed or inadvertently manipulated into an unsafe condition. Dropping or jarring a loaded firearm can cause accidental discharge. This can occur even with the "safety" in the "safe" position. Be extremely careful while hunting or during any shooting activity to avoid dropping any firearm.

Human error is a more likely reason for a firearm safety to fail. By mistake, you may think the safety is on when it really isn't. The safety may have been disengaged without your knowledge or you could think your rifle is unloaded when there's actually a cartridge or shell in it. A mechanical safety is not a substitute for common sense. It's merely a supplement to your proper and careful handling of a firearm. The word "safety" describes a firearm's trigger block mechanism, sear block mechanism, hammer block mechanism or firing pin block mechanism. Mechanical "safeties" are design to place your firearm in a safer status, and no guarantee can be made that the firearm will not fire even when the "safety" is in the "safe" position.

Never touch the trigger on a firearm until you are ready to shoot. Keep your fingers away from the trigger when you're loading or unloading. And don't pull the trigger when the safety is engaged or positioned between safe and fire.

Before using your firearm, read this instruction book to understand the exact location and operation of your firearm's safety. Even when the safety is on, maintain strict control of your loaded firearm and control the direction of the muzzle. In other words, never rely on your safety to justify careless handling. If your firearm's internal mechanisms are broken or have been altered, your firearm may fire even when the safety is on. While it is a good idea to "test" your firearm's mechanical safety periodically for proper function, never test the safety while your firearm is loaded or pointed in an unsafe direction. Remember, you and your safe firearm handling practices are your firearm's best safety.

1.4. Use proper ammunition

Every firearm is designed to use a certain caliber or gauge of ammunition. Using the wrong ammunition, mixing ammunition or using improperly reloaded ammunition can cause serious personal injury or death. It only takes one cartridge or shotshell of the incorrect caliber or gauge, or which has been improperly reloaded, to destroy your firearm. It's your responsibility to make sure the ammunition you use exactly matches the caliber or gauge of your firearm. Refer to this instruction book to find out the specific requirements of your firearm. Always read and follow the instructions on ammunition boxes. Never store cartridges of mixed calibers in a common container or in your pockets.

Confusing shells or cartridges can cause serious personal injury or death and destroy your firearm. Examine your cartridges closely and use only the precise caliber or gauge designed for your specific firearm.

Check all ammunition before you load it to make sure it matches your firearm's requirements. Cadex cannot assume any responsibility for the use of unsafe or improper firearm and ammunition combination or damage or injury caused by damaged ammunition. It is your responsibility to read and follow all warnings in this owner's manual and on ammunition boxes.

Every cartridge and shell is head-stamped with its caliber or gauge for easy identification. Likewise, you'll find the caliber of your new Cadex firearm imprinted on the barrel.

Use only SAAMI or CIP approved ammunition. The barrel and action of this firearm have been made with substantial safety margins beyond the pressures developed by established American commercial loads. Nevertheless, we can assume no liability for incidents which occur through the use of cartridges with nonstandard dimensions or which develop pressures in excess of commercially available ammunition which has been loaded in accordance with standards established by Sporting Arms and Ammunition Manufacturer's Institute (SAAMI) or The Commission Internationale Permanente (C.I.P.).

Reloading requires extra diligence.

If you're an ammunition reloader, you are responsible for personally assuring that the loads and components of your reloaded ammunition meet your rifle's factory-tested standards. Never use ammunition which has been reloaded by someone else!

Many shooters handload as a hobby or to save money on commercial, factory-made ammunition. However, it requires a thorough knowledge of reloading procedures and a deep respect for the explosive potential of gunpowder.

Firearms are designed, manufactured and tested to standards based on factory-loaded ammunition. Handloaded or reloaded ammunition that deviates, either intentionally or accidentally, from load or component recommendations can be very dangerous.

Reloaders must observe all possible safety precautions and practices related to the proper handling of explosives. Whether you're a seasoned reloader or just starting out, you should study the subject, watch reloading demonstrations and talk to experienced reloaders.

The first rule of reloading is to always follow the manufacturer's instructions for the components you're using. They'll tell you to follow certain guidelines. Namely:

1. Don't mix or substitute powders or primers.
2. Don't use unknown or substandard components.
3. Use only suitable components that have been factory-tested by reputable ammunition, powder and bullet manufacturers.
4. Always be sure to use the manufacturer's recommended recipe when reloading.

Not following these guidelines could result in severe injury or death to yourself or others or severe damage to your firearm. Dangerously high pressure and explosions can result from an overcharge of powder or other deviations from established reloading guidelines. Be very careful. The process of reloading exposes you to environmentally hazardous material. Lead, which is known to cause cancer and birth defects, is the most common substance in bullets and shot. It is important to handle lead bullets and shot with extreme care. Work only in a well ventilated area and always wash your hands after exposure and before eating. Never smoke while reloading.

Primers and powders are also highly toxic and flammable. So after reloading be sure to clean up all materials from your work area. Don't leave primer or powder spills anywhere on the floor or bench top. Dispose of all waste material in accordance with the manufacturer's recommendations.

Finally, when reloading or hand loading, concentrate on what you're doing at all times. Do not be distracted by talking to others, listening to the radio or watching TV while reloading. Never reload after consuming alcoholic beverages or drugs of any kind. You are working with extremely hazardous materials and you can't risk even a few seconds of distraction. Remember, if you reload, you are the ammunition manufacturer and you are responsible for the performance and safety of your reloaded ammunition.

1.5. Learn the mechanics and handling characteristics of your firearm

Not all firearms are alike. They have different mechanical characteristics that dictate how you should carry and handle them. Anyone who plans to use a firearm should first become totally familiar with the type of firearm it is and the safe handling procedures for loading, unloading, carrying, shooting and storing it.

Before you unpack your new Cadex firearm, read this instruction book in its entirety and familiarize yourself with the different components and parts of the firearm. Read, understand and follow the eleven rules of firearms safety contained within this manual.

1.6. Always wear eye and ear protection when shooting

Your sight and hearing risk injury from shooting and should be protected at all times. Wear protective shooting eye-wear to guard against falling shot, clay target chips, powder residue, ruptured cartridge cases and even twigs and branches in the field.

Also be sure to wear eye protection when you're disassembling or cleaning your firearm. Tensioned parts (like springs) and cleaning solvents can come in contact with your eyes. Always protect yourself.

Continued exposure to shooting noise can permanently damage your hearing. Always wear ear protection when shooting at the range or when shooting in confined areas.

1.7. Be sure the barrel is clear of obstructions before shooting

Before loading your firearm, open the action and make sure that the chamber and magazine are free of ammunition. Check the barrel for any obstructions or debris. Even a small amount of snow, mud, excess lubricant or grease in the bore can dangerously increase pressure and cause the barrel to bulge or burst when firing.

Use a cleaning rod and patch to wipe away anti-rust compounds or any other residues or obstructions in the barrel. **Never try to shoot out an obstruction by loading another shell and firing!**

If the noise or recoil of your firearm seems weak, stop everything, unload your firearm and be sure nothing is lodged in the barrel. Always be sure you're using the correct ammunition in your firearm and that it's free of obstructions.

1.8. Be sure of your target and what's beyond it

You can't stop a shot in mid-air, so never fire unless you know exactly where your shot is going and what it will strike. Never fire at a sound, a movement or a patch of color. A hunter in camouflage can easily be mistaken for a target by an impulsive shooter. Before you pull the trigger be absolutely sure of your target and what's behind it. Make sure the shot has a backstop such as a hillside or dense material like sand. Remember, bullets can travel great distances with tremendous velocity. Know how far your shot will go if you miss your target or the bullet ricochets.

1.9. If your rifle fails to fire when the trigger is pulled, handle with care

Be alert to the signs of ammunition malfunction. If you detect an off sound or light recoil when a cartridge is fired, do not load another cartridge into the chamber. If for some reason the ammunition doesn't fire when you pull the trigger, stop and remember the 1st rule of Firearm Safety – always keep the muzzle pointed in a safe direction.

Keep your face away from the breech, wait at least 30 seconds then carefully open the bolt, unload the firearm and dispose of the cartridge safely. Inspect the primer on the misfired cartridge if there is a firing pin signature or indent dispose of the cartridge in a safe manner. If the primer shows no signs of a firing pin signature or indent, your firearm should be examined by a qualified gunsmith and the cause of the malfunction corrected before further use.

Completely clear the barrel before loading and firing again. Failure to follow these instructions can cause extensive damage to your firearm and possible serious injury or death to yourself and others. Remember that any time there's a cartridge or shell in the chamber, your firearm is loaded and ready to use despite a misfire situation.

1.10. Never alter or modify your firearm and have it serviced regularly

Your firearm has been designed to operate according to certain factory specifications. by attempting to alter its trigger, mechanical safety or other mechanisms you're putting your safety and the safety of others at risk of injury or death. Never alter or modify your firearm in any way.

Proper cleaning, regular maintenance and lubrication are important to safe firearm functionality and are necessary to assure accuracy, safety and reliability. Before cleaning, always make sure that your rifle is completely unloaded. Many firearm accidents occur when a firearm is being cleaned, special and extreme care and caution should be taken to ensure that your firearm is unloaded before disassembly, cleaning and reassembly. Keep ammunition away from the cleaning location. Never test the mechanical function of any firearm with live ammunition. Always clean the barrel from the chamber end to the muzzle when possible.

Always clean and verify the firearm's bore before use. Verifying with a bore light or some other type of commercial bore verification tool is the safest and most effective way to verify that the bore is clean and free of obstructions. Be sure to clean your entire rifle before and after long-term storage and no less than once a year. It's also important to clean your firearm whenever it's been exposed to adverse conditions such as rain, dirt, mud, snow, sleet or saltwater.

For the safe and dependable operation of your firearm, all parts of your firearm must be properly cleaned and lubricated. Periodically inspect the internal workings of your firearm to be sure they are clean and free of rust, unwanted dirt and debris.

Use recommended lubricants on your firearms and do not over-lubricate. Excessive use of a non-recommended lubricant could adversely affect the function and safe operation of your firearm. Remember, you are responsible for the proper care and maintenance of your firearm. Failure to properly maintain your firearm can not only damage or ruin your firearm; it can expose you and others to unnecessary risks of personal injury or death.

Your firearm is a mechanical device which will not last forever, and as such, is subject to wear and requires periodic inspections, adjustment and service. Your Cadex firearm should be serviced by a Cadex factory certified service facility. We cannot assume any responsibility for injuries suffered or caused by unauthorized servicing, alterations or modifications of Cadex firearms. Do not, under any circumstances, alter the trigger, safety or other parts of the firing mechanism of this or any other firearm. Failure to obey this warning may result in injury or death to yourself or others.

1.11. Teach and supervise firearms safety to all members of your family

Closely supervise newcomers to the shooting sports. Encourage enrollment in hunting and shooting safety courses.

BE CAREFUL!

WARNING!

Discharging firearms in poorly ventilated areas, cleaning firearms or handling ammunition may result in exposure to lead, a substance known to cause birth defects, reproductive harm, cancer and other serious physical injury. Have adequate ventilation at all times. Wash hands thoroughly after exposure.

Never drink alcoholic beverages or take any type of drugs before or during shooting!

Your vision, motor skills and judgment could be dangerously impaired, making your firearm handling unsafe to you and others.

WARNING!

Failure to follow any of these safety rules may cause personal injury or death to the shooter or bystander and damage to property. Do not use a firearm until you fully understand and practice the eleven rules of firearm safety.

If you have any questions about the safe use of a Cadex Inc. firearm, write to us at:

Cadex Inc.
755 avenue Montrichard, Saint-Jean-sur-Richelieu
QC (Canada) J2X 5K8

Or call us at:
1-450-348-6774

Or visit our website at:
www.cadexdefence.com

2. CDX PRECISION RIFLE FEATURES

2.1. LITE configuration

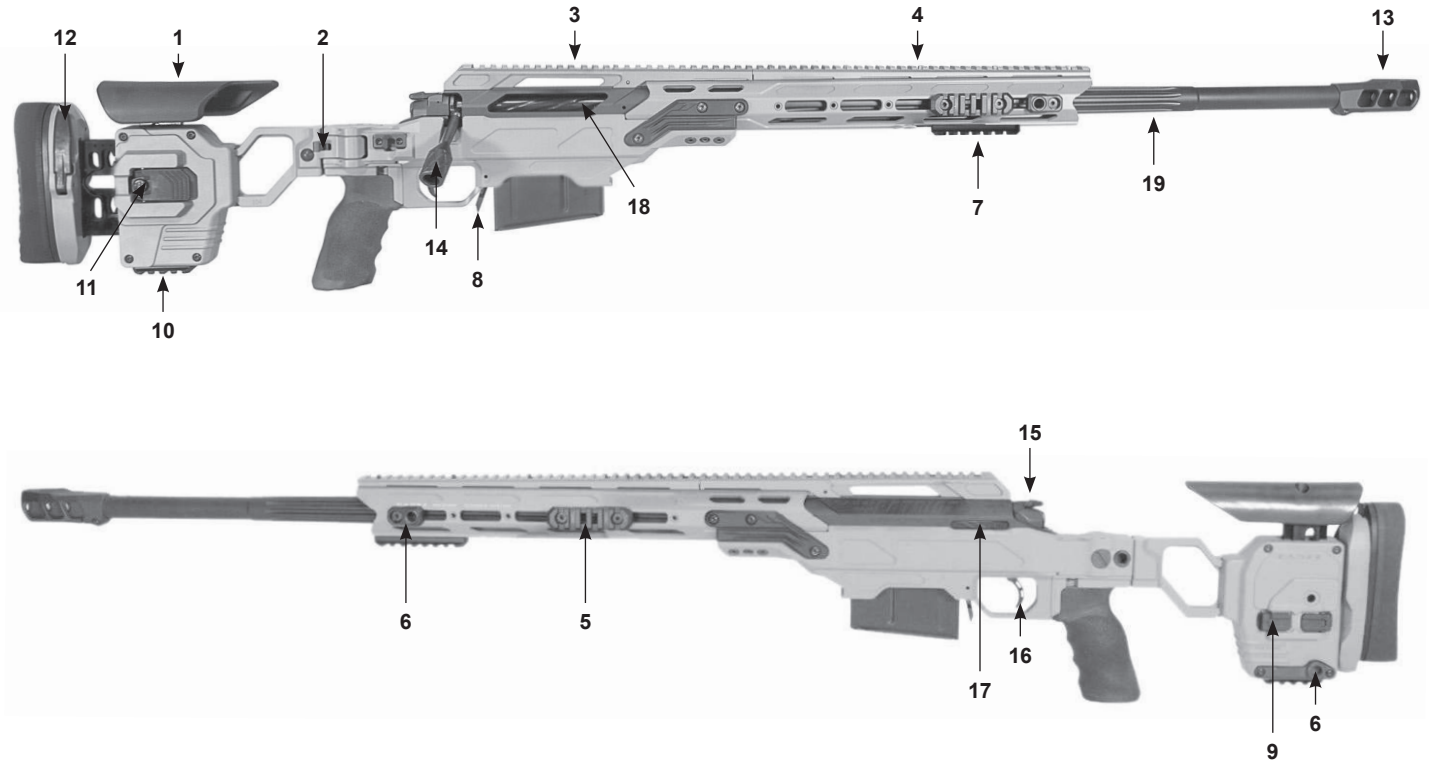

	CDX-30 LITE		CDX-300 LITE		CDX-33 LITE
Caliber	6 Creedmoor / 6.5 Creedmoor 6.5 PRC / 308 Win		300 PRC / 300 Rum		300 Norma Mag 338 Lapua Mag
Barrel length	20"	24"	24"	26"	27"
Weight*	13.4 lbs (6078 grams)	14.2 lbs (6441 grams)	14.2 lbs (6441 grams)	14.4 lbs (6531 grams)	14.5 lbs (6577 grams)
Overall length*	2.2" x 8" x 43" (5.6 x 20.3 x 109.2 cm)	2.2" x 8" x 46.44" (5.6 x 20.3 x 117.9 cm)	2.2" x 8" x 46.44" (5.6 x 20.3 x 117.9 cm)	2.2" x 8" x 48.44" (5.6 x 20.3 x 123 cm)	2.2" x 8" x 49.44" (5.6 x 20.3 x 125.58 cm)
Top rail	20 MOA / 30 MOA / 45 MOA				

**Weight and length with empty magazine and without muzzle brake*

KEY	PART	FUNCTION
1	Cheek piece	Provides a cheek rest and sufficient elevation adjustment for an operator to align aiming eye with various sighting systems.
2	Stock latch	Allows butt stock to fold to side of rifle for transport and shorten overall length.
3	Receiver top rail	Bolts to rifle receiver to provide stable MIL-STD-1913 mounting rail for attaching various optical sights or night vision sights or devices.
4	Forward rail and hand guard tube	Shields the barrel, serves as a rifle fore-end and provides attachment points for clip-on night vision devices, bipod, sling and various other rail mounted lights, pointers or other accessories.
5	Side rail	Provides attachment surface for lights, pointers or other accessories.
6	Sling mount	Mounting sockets to attach quick detach type sling swivels.
7	Bipod mount	Provides a means to attach various types of bipods.
8	Magazine release	Retains and releases box magazines.
9	Cheek piece elevation latch	Allows operator to raise or lower cheek piece.
10	Rail	MIL-STD-1913 rail for attaching monopod type devices.
11	LOP latch	Latch mechanism to allow changing stock for LOP adjustment.
12	Butt plate latch	Latch mechanism to allow the butt plate to adjust up or down.
13	Muzzle brake	Reduces felt recoil and improves rifle stability.
14	Bolt handle	For opening and closing the bolt.
15	Safety lever	Allows operator to block/release the firing pin.
16	Trigger	Fully adjustable trigger (single or dual stage) allows for the precise increase or decrease of trigger pull weight.
17	Bolt release	Allows the operator to remove the bolt from the receiver.
18	Bolt	For inserting a cartridge into the chamber.
19	Barrel assembly	Allows the projectile to be precisely fired from the firearm.

2.2. TAC configuration

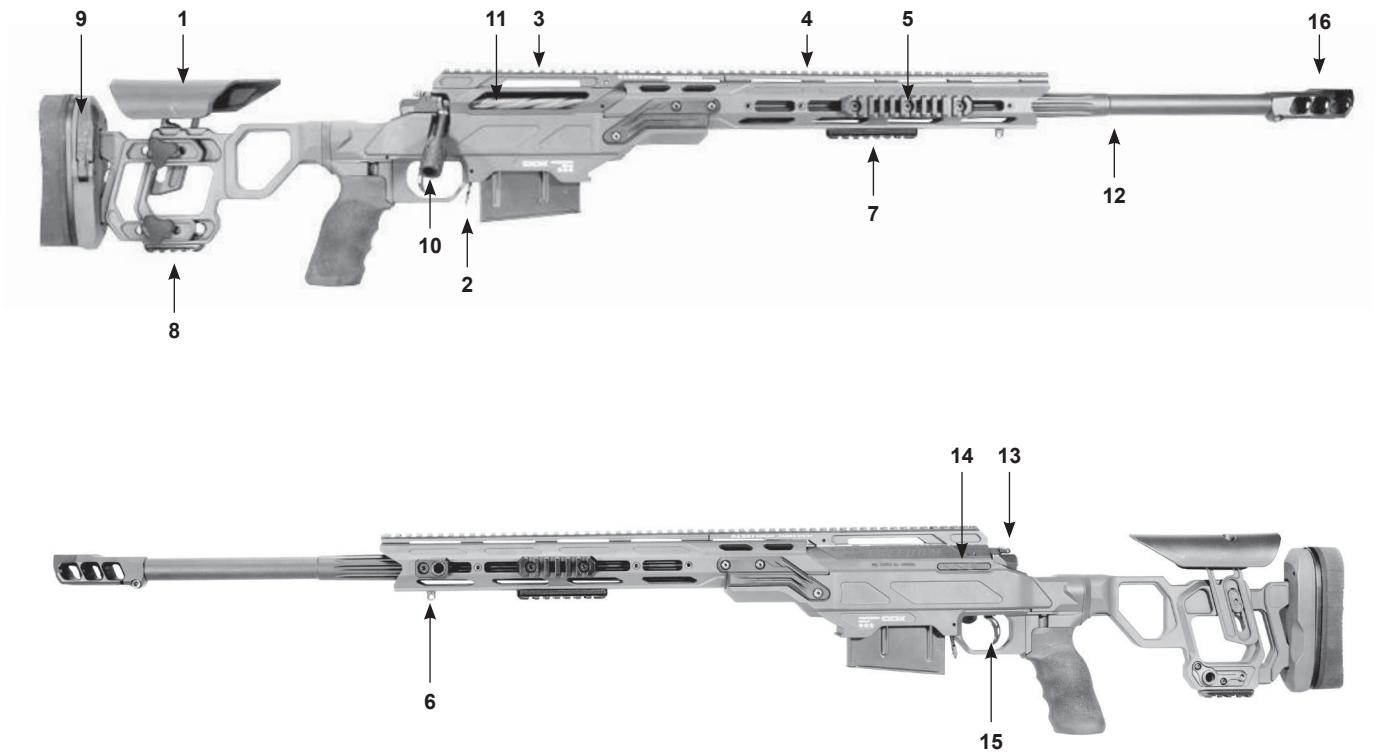

	CDX-30 TAC		CDX-300 TAC		CDX-33 TAC
Caliber	6 Creedmoor / 6.5 Creedmoor 6.5 PRC / 308 Win		300 PRC / 300 Rum		300 Norma Mag 338 Lapua Mag
Barrel length	20"	24"	24"	26"	27"
Weight*	12.2 lbs (5536 grams)	13 lbs (5899 grams)	13 lbs (5899 grams)	13.2 lbs (5989 grams)	13.3 lbs (6035 grams)
Overall length*	2.2" x 8" x 43" (5.6 x 20.3 x 109.2 cm)	2.2" x 8" x 47" (5.6 x 20.3 x 119.4 cm)	2.2" x 8" x 47" (5.6 x 20.3 x 119.4 cm)	2.2" x 8" x 49" (5.6 x 20.3 x 124.5 cm)	2.2" x 8" x 50" (5.6 x 20.3 x 127 cm)
Top rail	20 MOA / 30 MOA / 45 MOA				

**Weight and length with empty magazine and without muzzle brake*

KEY	PART	FUNCTION
1	Cheek piece	Provides a cheek rest and sufficient elevation adjustment for an operator to align aiming eye with various sighting systems.
2	Magazine release	Retains and releases box magazines.
3	Receiver top rail	Bolts to rifle receiver to provide stable MIL-STD-1913 mounting rail for attaching various optical sights or night vision sights or devices.
4	Forward rail and hand guard tube	Shields the barrel, serves as a rifle fore-end and provides attachment points for clip-on night vision devices, bipod, sling and various other rail mounted lights, pointers or other accessories.
5	Side rail	Provides attachment surfaces for lights, pointers or other accessories.
6	Sling mount	Mounting sockets to attach quick detach type sling swivels.
7	Bipod mount	Provides a means to attach various types of bipods.
8	Rail	MIL-STD-1913 rail for attaching monopod type devices.
9	Butt plate latch	Latch mechanism to allow the butt plate to adjust up or down.
10	Bolt handle	For opening and closing the bolt.
11	Bolt	For inserting a cartridge into the chamber
12	Barrel assembly	Allows the projectile to be precisely fired from the firearm.
13	Safety lever	Allows the operator to block/release the firing pin.
14	Bolt release	Allows the operator to remove the bolt from the receiver.
15	Trigger	Fully adjustable trigger (single or dual stage) allows for the precise increase or decrease of trigger pull weight.
16	Muzzle brake	Reduces felt recoil and improves rifle stability.

2.3. Caliber designation

Before loading always insure that you are using ammunition that matches the caliber inscription found on your rifle's barrel. **WARNING! Using the wrong ammunition, mixing ammunition or using improperly reloaded ammunition can cause serious personal injury or death.**



3. IMPORTANT PARTS OF THE FIREARM

3.1. The safety mechanism

The safety mechanism provides protection against accidental or unintentional discharge under normal usage when properly engaged and in good working order. The safety mechanism is not a substitute for following the rules of safe firearm handling.

To engage the safety mechanism, the bolt shall be entirely closed and locked. Then, push the safety mechanism lever fully to the left. The “green” indicator will appear.



Always put the safety mechanism in the “green” position before handling the firearm. Pushing the safety mechanism to the right will reveal a red indicator; this indicates that the firearm is ready to fire.



Do not touch the trigger while moving the safety mechanism. Your fingers and all other objects should be kept outside of the trigger guard and away from the trigger until you are actually ready to fire by pulling the trigger.

WARNING! The firearm will fire when the trigger is pulled and the safety mechanism is in the “red” position. Even when the safety mechanism is in the “green” position, careless handling can cause the firearm to fire.

3.2. The locking system

This firearm is equipped with a locking system that locks the bolt in the close position. When the safety mechanism is engaged (“green” position), the bolt handle cannot be moved upward to open the bolt. To unlock the bolt, the safety mechanism shall be moved to the “red” position.

3.3. The bolt assembly

A. To install bolt assembly (the bolt assembly locks the cartridge into the chamber)

1. Always point the firearm in a safe direction.
2. Align the lugs on the bolt assembly with the receiver. The bolt handle will be in the open position.
3. Slide in the bolt until the bolt handle reaches the bolt handle seat.



4. To place the bolt assembly in closed position, push the bolt handle down.
5. **Be careful.** Your rifle is now on fire position and could discharge accidentally.
6. Put the safety mechanism on the “green” position.

B. To remove bolt assembly

1. Always point the firearm in a safe direction.
2. Put the safety mechanism in the “red” position.
3. Do not touch the trigger while moving the safety mechanism.
4. **Be careful.** Your rifle is now on fire position and could discharge accidentally.
5. Raise the bolt handle.
6. Pull the bolt handle all the way back.
7. Push the bolt stop release on the left side of the receiver.
8. Slide the bolt assembly away from the firearm.

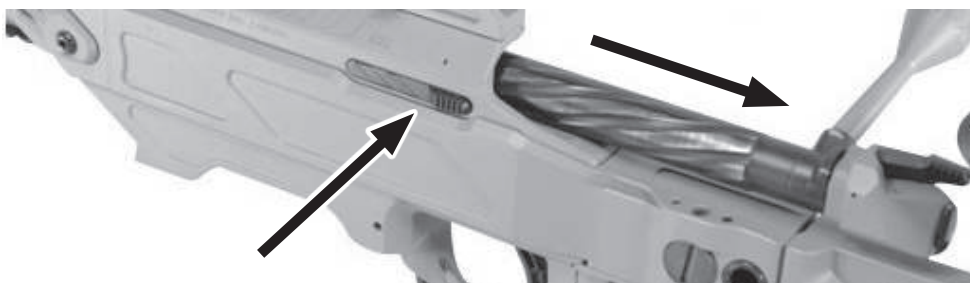

C. Disassembling the bolt assembly

The bolt assembly can be disassembled for cleaning and maintenance purpose.

WARNING! Do not modify any parts of the bolt assembly. Modification of the firing system can cause safety issues.

D. Removing the firing pin assembly

1. Remove the bolt from the action.
2. Turn the shroud clockwise (when facing the rear of the bolt) until the firing pin assembly is released from the bolt.

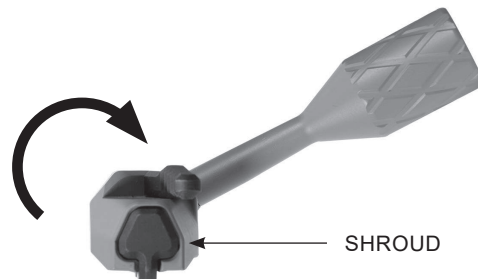

3. Pull the firing pin assembly backward and remove it from the bolt assembly.

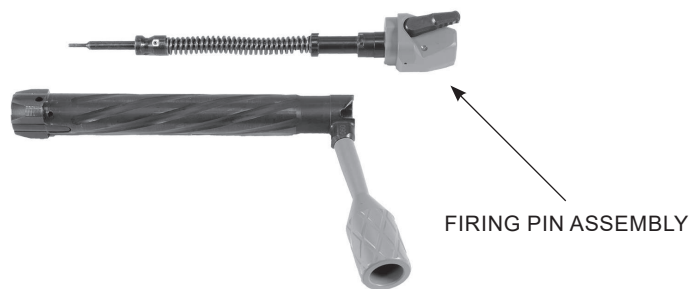

E. Reassembling the firing pin assembly

1. Insert the firing pin assembly in the bolt assembly.

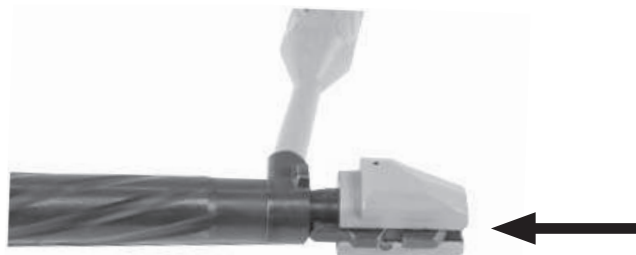

2. Push hard (until the shroud face is in contact with bolt rear face) and turn the shroud slowly counterclockwise until it locks in place.



This document contains information that is proprietary to Cadex Inc. Neither this document nor the information contained herein shall be used, duplicated or communicated by any means to any third party, in whole or in part, except with the prior written consent of Cadex Inc. This restrictive legend shall not be altered or obliterated from this document.

3.4. The trigger assembly

Pulling the trigger fires the firearm. The trigger assembly on your rifle comes with a trigger pull weight adjustment. Adjusting the trigger pull weight does not require disassembly from the rifle.

WARNING! Only the trigger pull weight is adjustable. For safety's sake, NEVER make adjustments or alterations to any other parts of the trigger assembly or rifle.

WARNING! Do not make dry firing on your rifle when doing adjustments. This can affect the rifle safety and can void the warranty. Use of snap caps is strongly recommended.

WARNING! NEVER put your finger on the trigger unless you are going to fire the firearm.

DX2 EVO TRIGGER

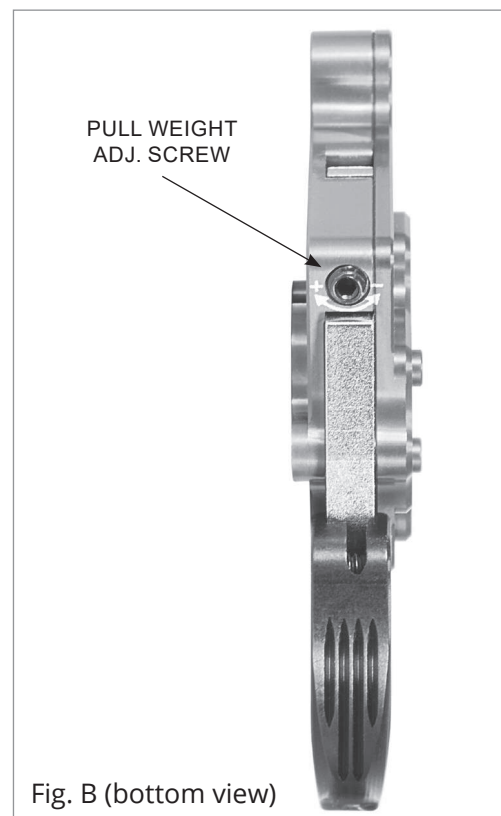
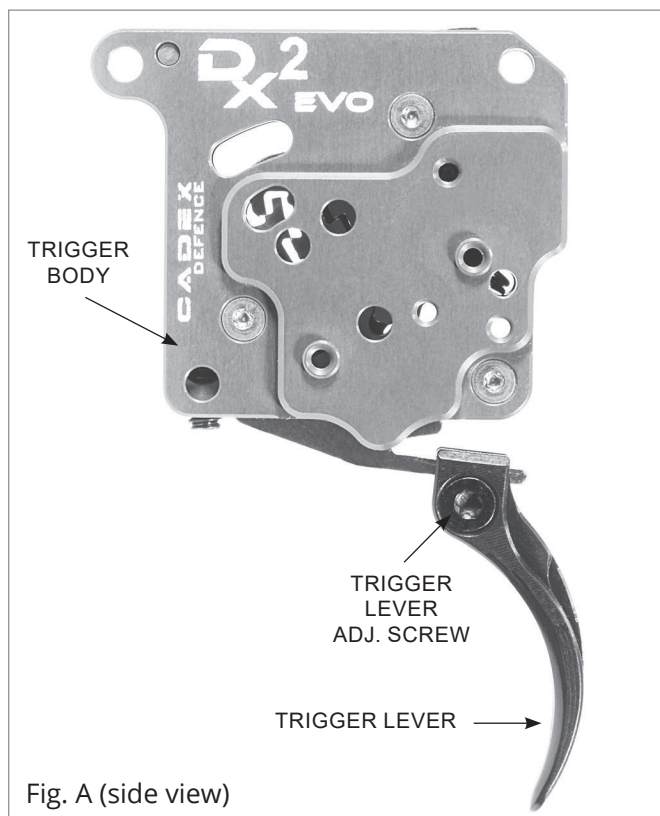

A. Trigger pull weight adjustment

The trigger of your rifle has been pre-set at the factory in conformity with industry guidelines to provide the better performance of the product. Cadex do not recommend user to adjust the pull weight outside of the pre-define range. However, for competition target shooters firing the rifle from a secure stationary rest in a controlled environment, the trigger pull force can be adjusted downward by the user or a qualified gunsmith using the procedure set forth below.

WARNING! Adjustments below two (2) pounds (0.91 kg) of trigger pull weight should only be made for a rifle being used in competitive target shooting and fired from a secure stationary rest in a controlled environment. When lowering the trigger pull weight, it is the user responsibility to verify the trigger and rifle safety and Cadex will not be responsible for any problems related with a trigger pull weight below two pounds.

For any other purpose, including use in the field, the trigger pull weight on your rifle should NEVER be reduced below two (2) pounds (0.91 kg).

Remember – regardless of the amount of trigger pull weight, ALWAYS keep the muzzle of your rifle pointed in a safe direction to prevent injury or death caused by an unintended or accidental discharge.

WARNING! With the bolt removed, check the chamber and magazine of the rifle to make sure there are no cartridges in the rifle. NEVER attempt to adjust the trigger pull weight on a loaded rifle.

NOTE: The trigger needs to be installed on the receiver for pull weight adjustment.

1. Remove the bolt from the action.
2. Remove the detachable base from the chassis. (See section 3.10. - B for the detailed procedure)
3. Second stage adjustment (only the second stage is adjustable): using a 1/16" Allen key, slowly turn the pull weight adjustment screw clockwise to increase the trigger pull weight. Turning the screw counterclockwise will reduce the trigger pull weight. **Caution! Please note that the full range of the trigger pull weight adj. screw is from "Flush" with the trigger body up to three (3) complete turn (see below).**

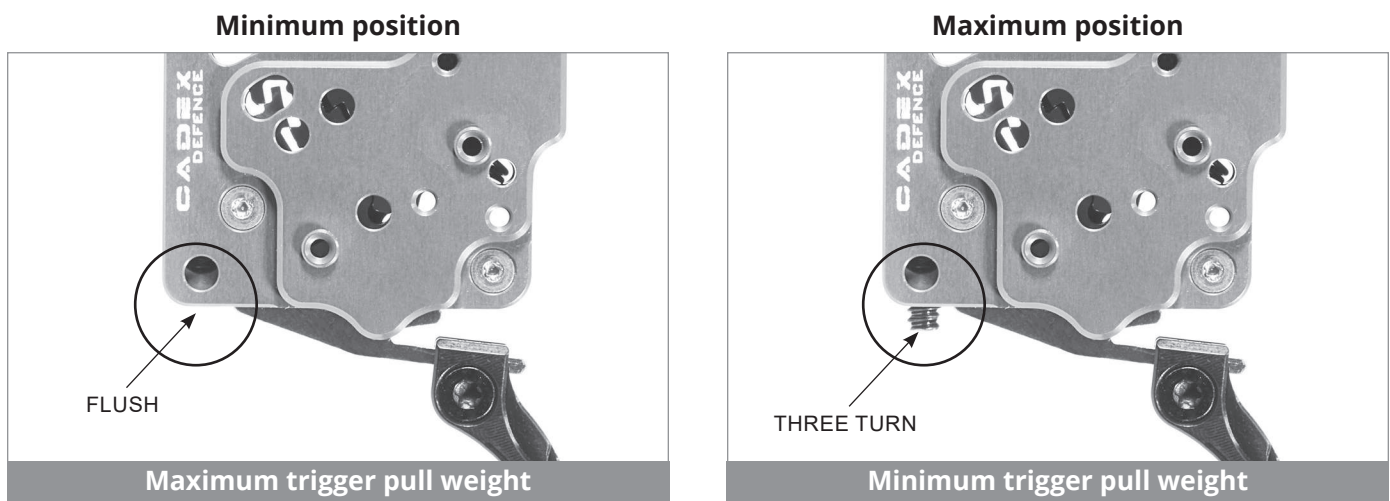

4. Reinstall the bolt into the action.
5. Close the bolt and put the safety to the "red" position.
6. With a trigger pull gauge, pull the trigger backward until the sear releases the firing pin.
7. Record the value of the pull weight.
8. If the desired trigger pull weight has not been achieved, repeat steps 3 through 7.

B. Trigger lever position adjustment

The trigger can be adjusted forwards/backwards to accommodate shorter/longer fingers.

1. Using a T8 torx driver, turn the locking screw counterclockwise.
2. Slide the trigger lever to the desired position.
3. Turn the screw clockwise to tighten into place (hand tighten, use low-strength purple loctite).
Pay attention to not over tight.

C. Single stage vs double stage conversion

The trigger can be converted from a double stage to a single stage trigger. **Note: Only the second stage pull weight is adjustable.**

1. Using a 5/64" Allen key, remove the screw.

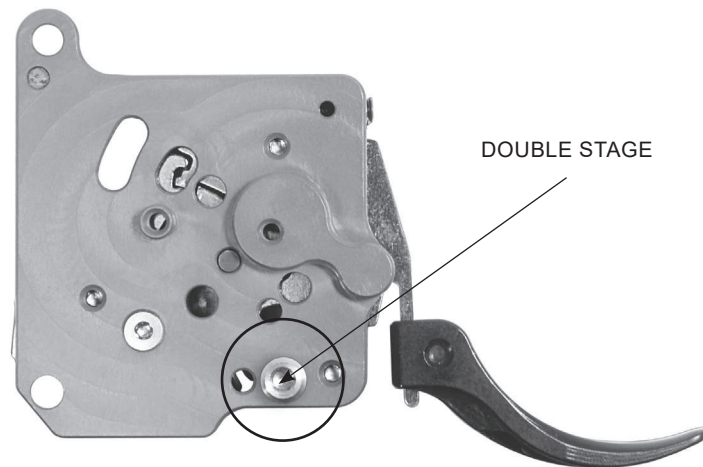

2. Insert the screw into the first stage hole. It may be necessary to pull the trigger lever a little bit to give access to the screw.

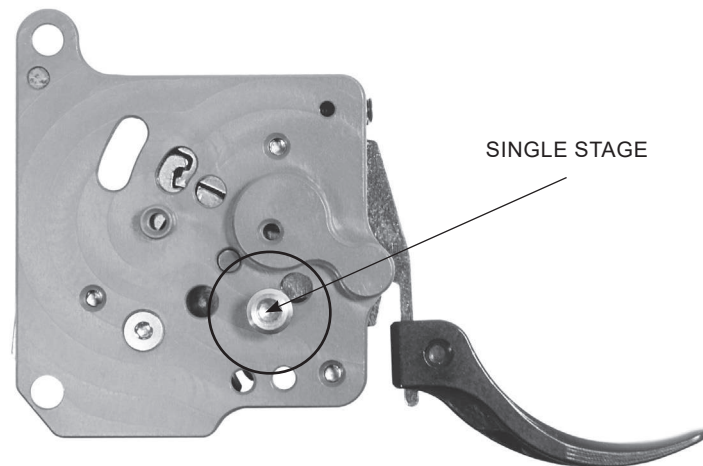

3. Fully tighten the screw and torque it to a max of 6 in-lbs.

D. Trigger cleaning and maintenance

See section 5.3. for details.

3.5. The barrel

The inside of the barrel must be clean and free of obstructions.

A. New firearm break-in procedure

For the best results and long life of your rifle barrel, we suggest the following break-in procedure:

1. Thoroughly clean the barrel before shooting, following the instructions in section 5.2. Always clean the barrel from the chamber end towards the muzzle.
2. With the bolt removed and the bore guide (optional item) in place, start by pushing a solvent wet patch through the bore, followed by 20 strokes of a solvent soaked bronze brush. Dry patch the barrel until patches come out clean and dry. Remove the bore guide and run a final dry patch through chamber and bore. Install the bolt. The rifle is now ready for the first shot.
3. Fire one round and reclean the bore as stated in the previous step. In order to break in the barrel correctly it is critical to remove all traces of fouling. After the initial bore cleaning has been completed, run several patches soaked in the copper remover completely through the barrel. Dry patch after each wet patch. Once there is no trace of copper in the bore and the patches come out clean and dry, fire the next round. Repeat this procedure for the first 10-12 rounds.
4. When you have completed this initial single shot sequence, you may proceed to the next step. Shoot two (2) shots and clean, for a total of twenty (20) rounds. At no time should the barrel be allowed to get so hot that you cannot hold it comfortably in your hands.
5. CAUTION: Do not use any kind of abrasive cleaner in the bore.

B. To check the inside of the barrel

1. Point the firearm in a safe direction.
2. Put the safety mechanism in the “red” position.
3. Remove the bolt from the action.
4. Remove any ammunition from the chamber and remove magazine.
5. Look through the inside of the barrel from the chamber end to the muzzle.

C. To remove object from inside the barrel

1. Use correct size cleaning rod.
2. Push cleaning rod from the chamber end all the way through the barrel, until the rod comes out of the muzzle.
3. If an object cannot be easily pushed out of the barrel with a cleaning rod, return the firearm to the factory or a QUALIFIED GUNSMITH.

WARNING! NEVER try to remove an object from the barrel by loading another cartridge and firing. This may cause the barrel to burst or a cartridge case to rupture and cause serious personal injury or death.

D. To clean the barrel

Follow the instruction on section 5.2.

3.6. The muzzle brake

The Cadex MX1 muzzle brake is designed to deflect the muzzle blast away from the shooter and his spotter. Gases exit sideways and upward to reduce the felt recoil, dust cloud and improve rifle control.

Assembly procedure

WARNING! Do not tight the screw when the muzzle brake is not installed on a barrel. This may permanently damage the muzzle brake and the barrel threads.

1. If your barrel is fitted with a thread protector cap, remove it to access the muzzle threads.
2. Cadex suggests to apply a light film of lubricant on the muzzle threads such as anti-seize grease.
3. Screw (clockwise) the Cadex muzzle brake on the muzzle until it reaches its limit. Then back off a little bit (less than a full turn) to align the muzzle brake with your rifle. For maximum effectiveness the top of the muzzle brake must be parallel to the ground when your rifle is levelled.
4. Install the screw and tight it with a torque of 45 in-lbs (5.08 N-m).
5. Your muzzle brake is now installed.

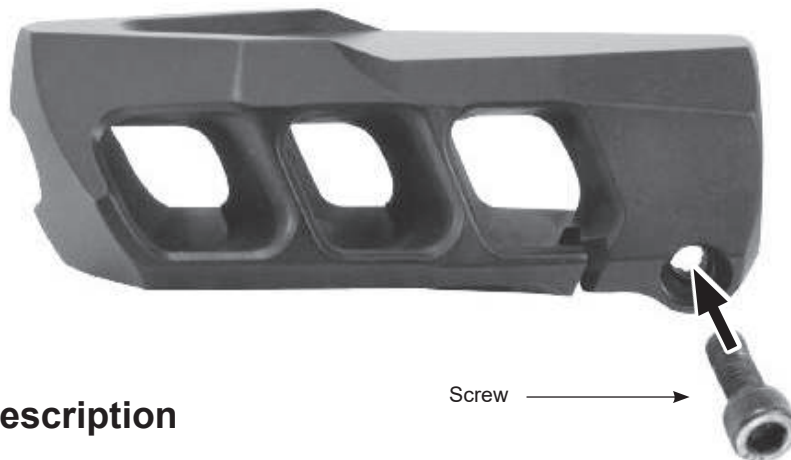

3.7. Chassis description

1. The Cadex chassis is an integrated system to enhance the handling and portability of sniper rifles. The chassis is designed to make the sniper rifle a modular system that allows the sniper to tailor the rifle to specific mission needs. It incorporates a dual rail, a long fore-end tube with modular rails, folding butt stock (Lite version), and sling mounting points.
2. The fore-end tube provides a mounting surface for the tube top rail and accessory rails. A rail and/or bipod stud is located at the forward-most bottom of the tube. This positions the bipod far forward of the rifles center of mass, which allows the sniper better control of the rifle under recoil, for better shot follow through.
3. The butt stock is user adjustable without tools for length of pull, cheek piece height and recoil pad height.
4. The Lite version of the chassis system incorporates a folding butt stock to improve portability of the rifle and reduce visual signature of the sniper by lowering the sniper rifle's overall length. Butt stock folds to the right to cover and protect the bolt handle.
5. The chassis features a detachable base whereby the magazine well and pistol grip assemblies are removed from the chassis center section to allow access to the trigger mechanism in order to perform trigger adjustments and maintenance.
6. The chassis uses AICS style magazines (SSSF or DSSF). Magazine catch is incorporated into the lower and is a lever type catch that engages the lug on the back (or front) of the magazine.

3.8. Operation of stock controls (LITE configuration)

A. Adjusting length of pull

Length of pull (LOP) is adjusted by pulling the extension latch (1) and then by pulling or pushing recoil pad to desired position (2). The adjustment mechanism has clicks that can be felt as the mechanism is adjusted. Once the position is attained, press in on the extension latch to lock the stock.

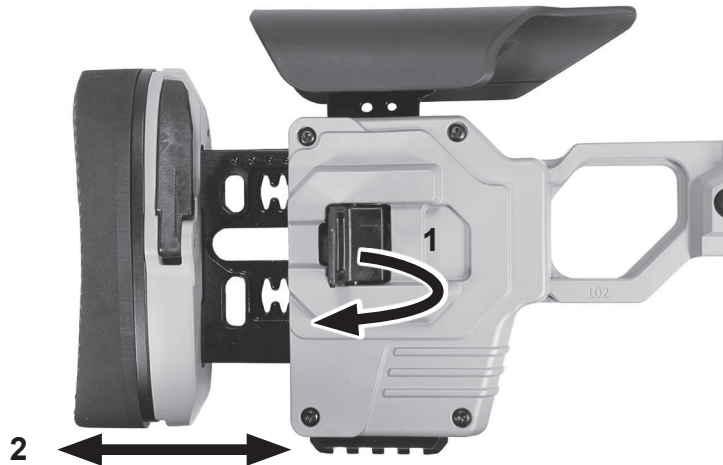

B. Adjusting the length of pull locking mechanism

The length of pull (LOP) locking mechanism can be adjusted to obtain the desired tension into the latch. A screw is located inside the butt stock and is accessible by a hole located on the left side of the butt stock. Please note that the locking mechanism is factory adjusted and should not be modified unless the mechanism becomes loose.

1. The extension latch lever should be in the close position prior to adjust the tension.
2. Insert a flat screw driver (3/16" wide is suggested) into the side hole. Turn the screw driver clockwise to bring more tension into the latch lever until the movement become more difficult. A torque of 10 in-lbs (1.1 N-m) is suggested and it should not be more than 13 in-lbs (1.4 N-m).

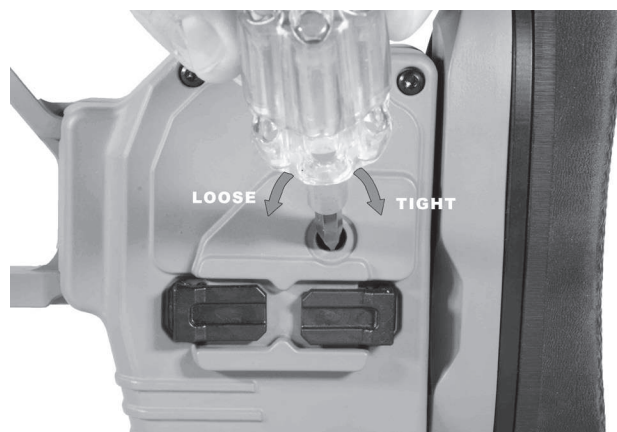

3. Verify that the latch lever work well by doing a length of pull adjustment (the procedure is described in section 3.8 - A).

C. Adjusting height of cheek piece

1. Cheek piece is adjustable to place shooters eye in the optimum position with the optic and to provide a comfortable cheek support.
2. Cheek piece height is adjusted by simultaneously pressing on the height adjustment catches (1) and raising/lowering the cheek piece to the desired height (2). Releasing the spring loaded catches locks the cheek piece in place.

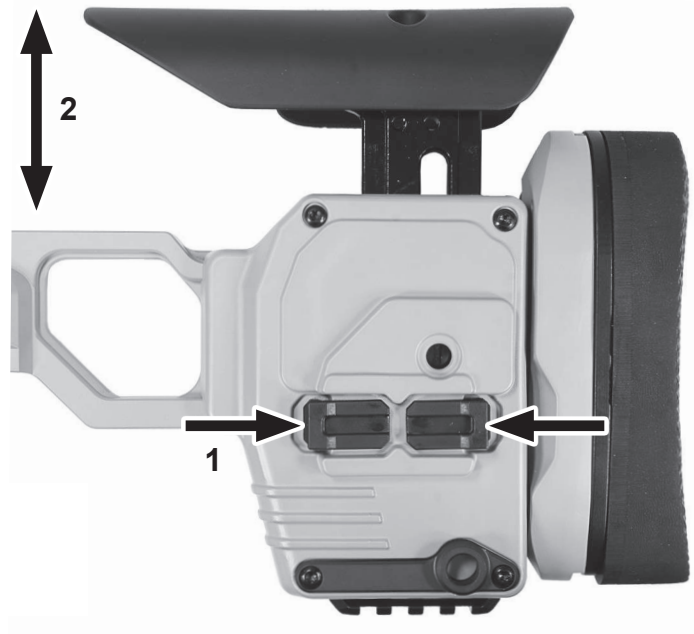

D. Adjusting height of recoil pad

1. The pad is adjusted vertically by pivoting the top of the lever outwards (1) and moving the recoil pad to the desired height (2). Rotate the top of lever inwards to lock the recoil pad.



E. Folding, extending and tightening the butt stock

1. To fold the butt stock, pull back the locking tab to disengage the lock (1), and fold the stock (2). When the stock is in the folded position, the lock tab will engage the latch plate on the side of the chassis to secure the butt in the folded position.

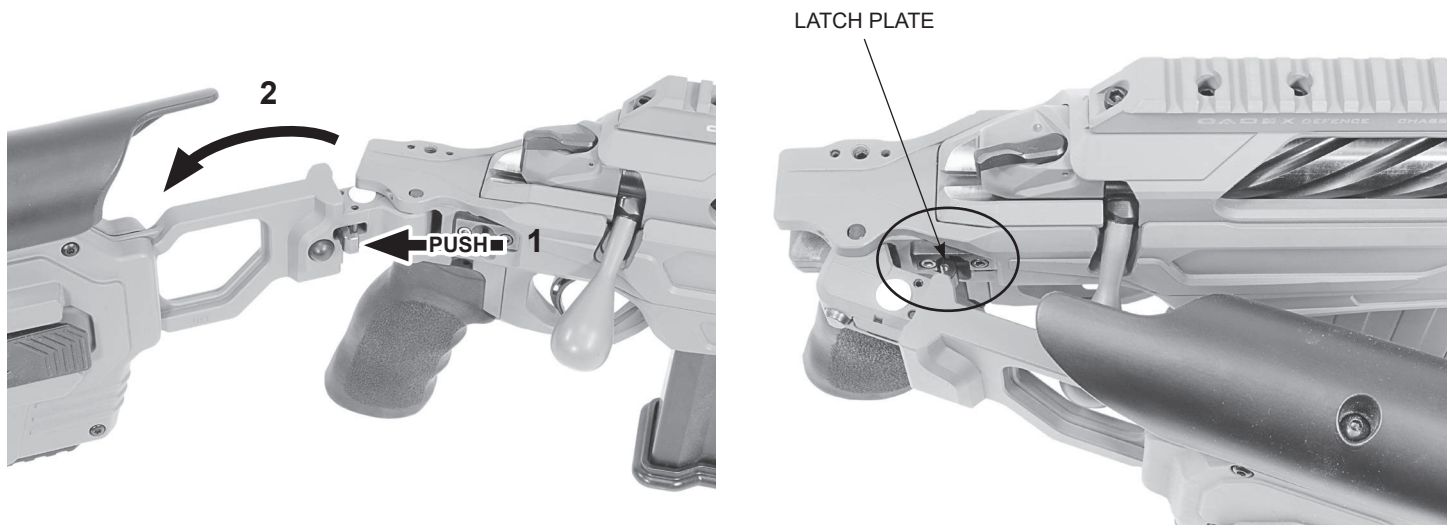

2. To extend the butt stock, slightly push the butt stock (1) to the chassis and then press the lock stud (2) and rotate the butt stock (3) fully to the extended position. Push the butt stock firmly into position, then attempt to move the butt to the right to ensure the lock mechanism is fully engaged. Do not apply excessive force when folding or extending the stock.



3. The butt folding mechanism can be adjusted using the adjustment screw located on the left side of the hinge. If the butt locking mechanism gets loose, unscrew the set screw located on the top of the chassis right over the adjustment screw, then tighten the adjustment screw until it can't be turned anymore. Finally, tighten the set screw to lock the adjustment screw in place. Note that the butt stock has to be fully extended and locked in place to perform this adjustment.

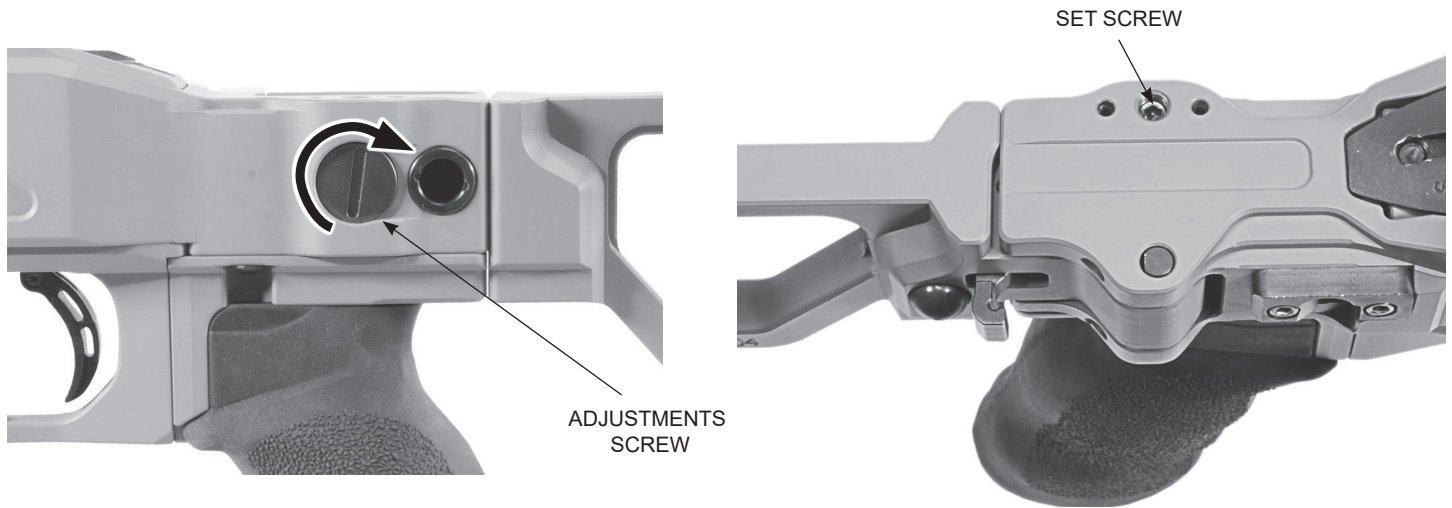

3.9. Operation of stock controls (TAC configuration)

A. Adjusting the length of pull

The length of pull (LOP) can be adjusted by removing the upper and lower knobs and the two locking sleeves (1). **Use caution when removing the top knob, this knob is also used to hold the cheek piece in place.**

Once removed, the butt pad may be moved forward or backward (2).

Once adjusted to the correct position, replace the locking pieces in their respective holes and replace the knobs.

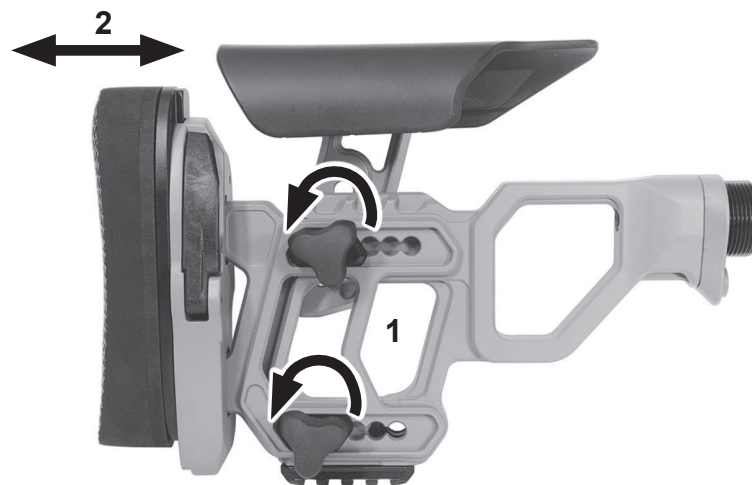

B. Adjusting the height of cheek piece

The cheek piece height adjustment is similar to the LOP adjustment but only the top knob and cheek piece locking nut need to be removed (1).

Once adjusted to the correct position (2), replace the locking nut and knob.

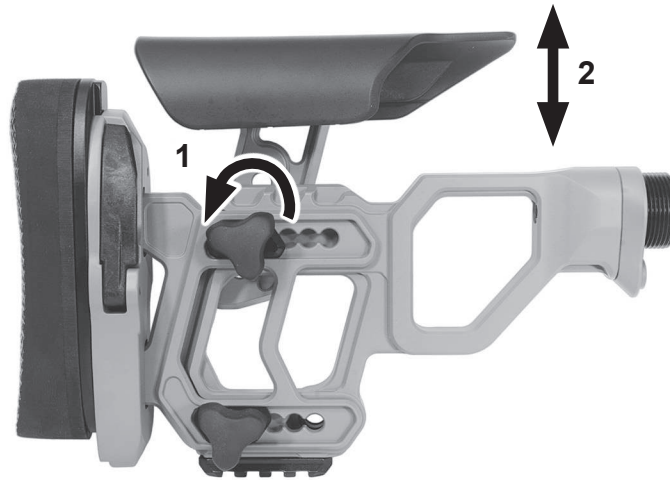

C. Adjusting the height of recoil pad

1. The pad is adjusted vertically by pivoting the top of the lever outwards (1) and moving the recoil pad to the desired height (2). Rotate the top of lever inwards to lock the recoil pad.

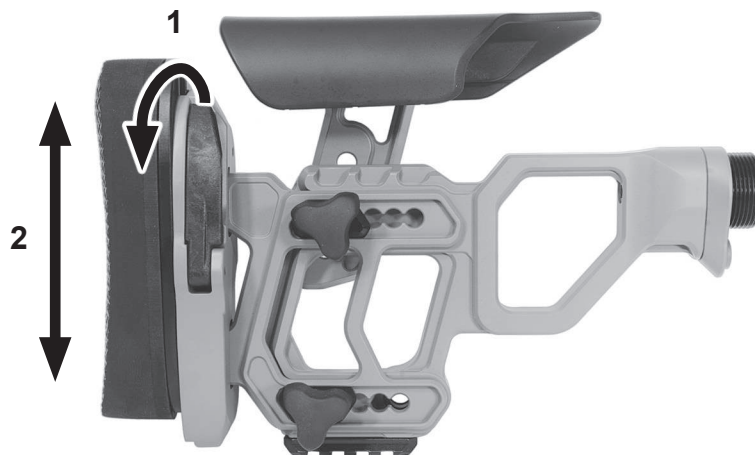

3.10. Disassembly of the firearm

Warning! Before any disassembly of the firearm and chassis, remove the bolt from the action, remove the magazine and check the chamber of the rifle to make sure there are no cartridges in the rifle. NEVER attempt to make any disassembly on a loaded rifle.

A. Top rail and fore-end tube disassembly

When chassis disassembly is required, perform the procedure that follows.

1. If removing optics from the top rail, note position of the rings on the Picatinny rail and the zero settings of optics for future reference. If equipped with a muzzle brake, removed it prior to proceed with the fore-end tube disassembly.
2. Disassemble the entire top rail by removing cap screws.

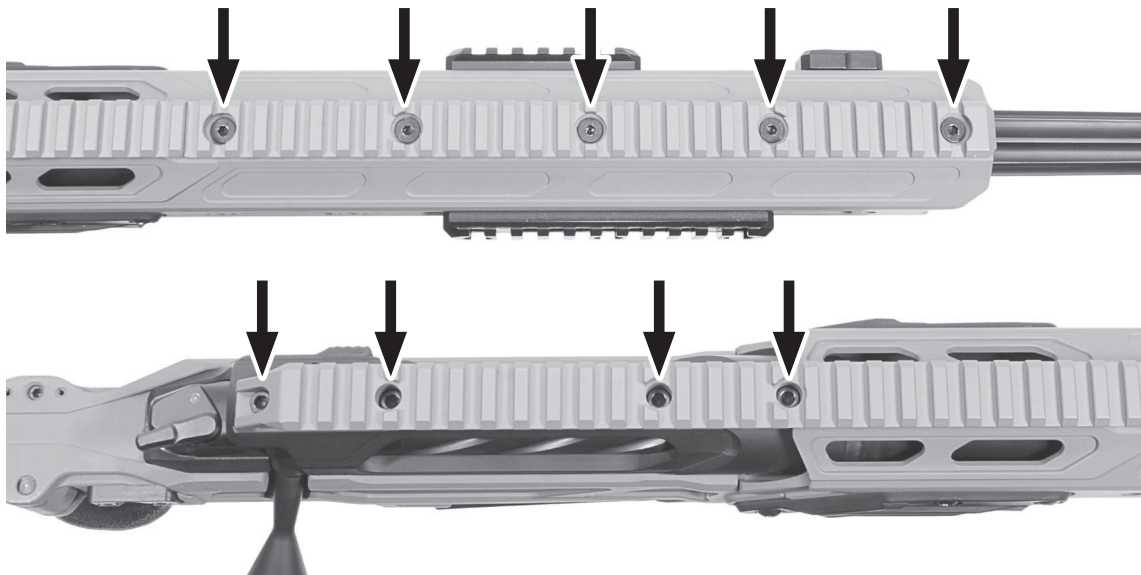

3. Remove the three (3) cap screws from each side plate (left and right), and remove the side plates from their recess. (If optional Short side rails are installed, remove rails prior to removing side plates)

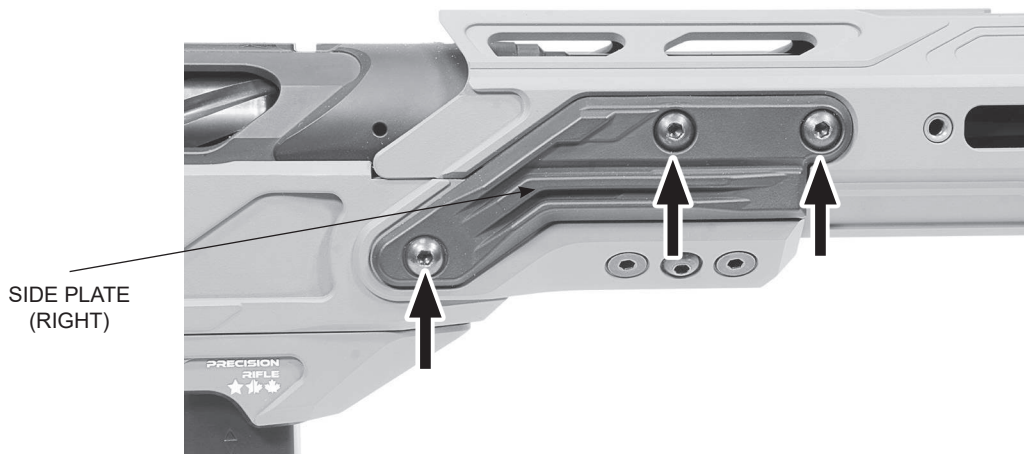

- Remove two (2) cap screws (A) securing fore-end tube from the bottom of the chassis. For the LITE version, the two (2) spare BHSCS (B) also need to be removed. Item (C) does not need to be removed.

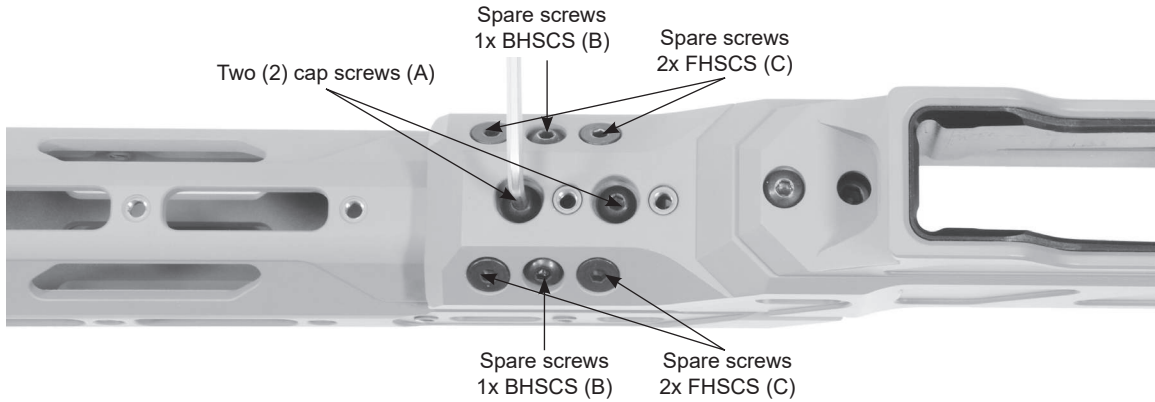

- Separate the fore-end tube from the chassis center section.

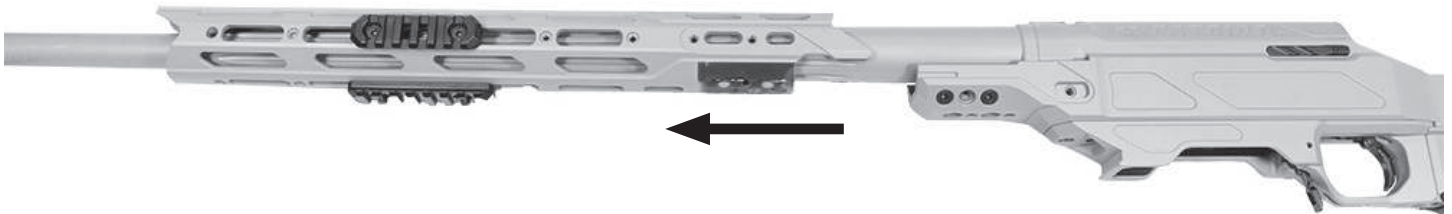

B. Removal of detachable base and magazine sleeve (if equipped)

The detachable base is a feature that allows access to the trigger group without having to remove the barreled action from the chassis.

- Remove the pistol grip and then remove the three (3) cap screws (item A) from the pistol grip mounting plate (item B), and remove the assembly from the chassis.
- Remove the cap screw (item C) located in front of the magazine well.
- Pull the detachable base (item D) away from the bottom of the chassis.
- At this step, maintenance and cleaning can be done for the action and trigger mechanism.

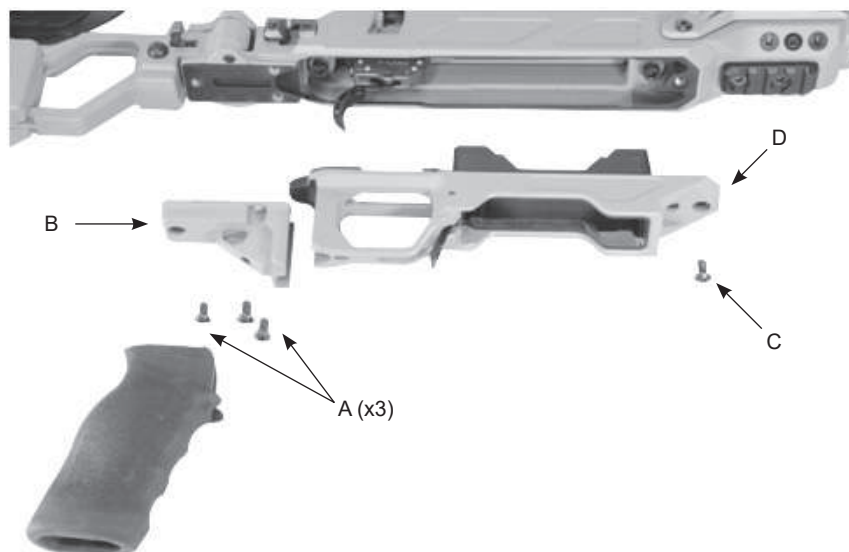

5. The magazine sleeve insert can be removed by pulling it out of the detachable base.

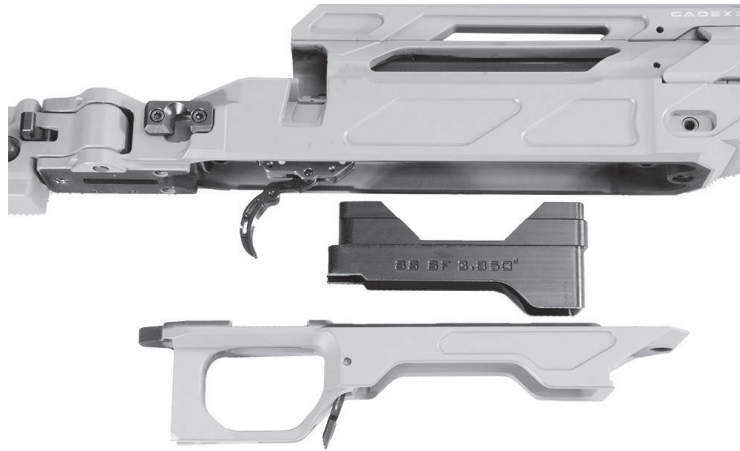

C. Removal of action from the chassis

The action can be removed from the chassis for cleaning and maintenance purposes.

1. Remove the top rail and the fore-end tube. (See previous step for details)
2. Using a 3/16" Allen key, unscrews the two (2) action screws located on the bottom surface of the chassis. Both screws will remain trapped inside the chassis if the detachable base is not removed. Note that it is not necessary to remove the detachable base to remove the action from the chassis.

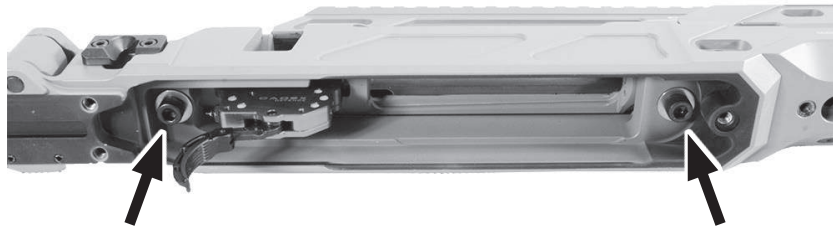

3. Slowly pull out the action from the chassis.
4. When the action is removed from the chassis, pay attention not to damage the "V" shapes located in the chassis and on the action bottom surface.

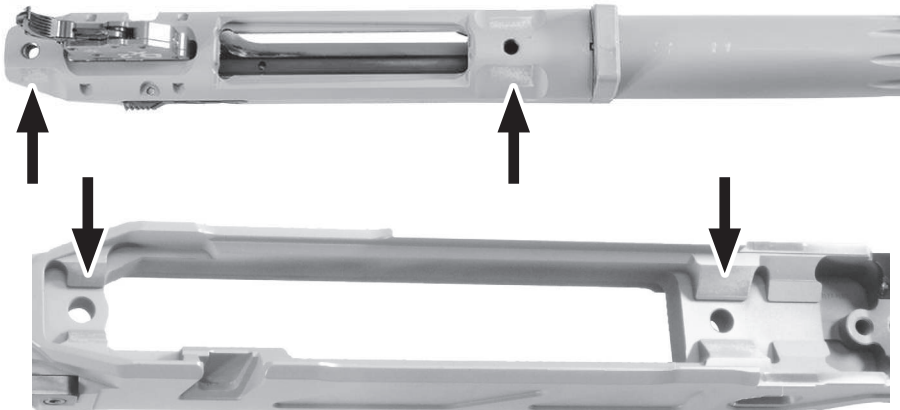

3.11. Assembly of the firearm

A. Installation of the action into the chassis

The barreled action is held to the chassis frame by conventional method using a front and rear action screw. The action rests on four flat surfaces that serve as front and rear V-blocks to support and center the action. Recoil is transferred via the rifle recoil lug to the rear surface of the lug mortise depicted below.

NOTE: Verify all four contact surfaces (on both chassis and action) are free of dirt, dent, or marks before installing the action into the chassis.

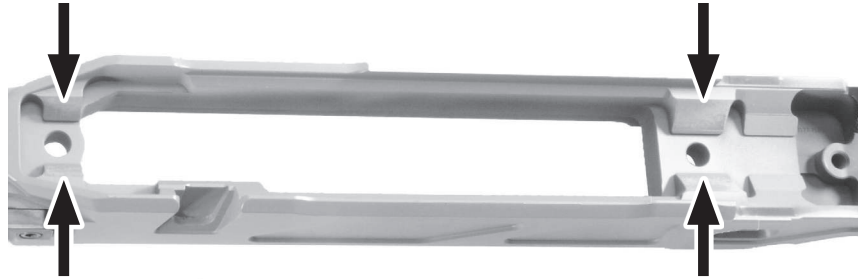

1. Make sure the fore-end tube is not installed on the chassis.
2. It is not necessary but it is suggested that the detachable base is removed prior to install the action into the chassis.
3. Insert the barreled action into the chassis frame.
4. Verify that the receiver fully inserts into the chassis and the rear face of the recoil lug is bearing against the rear face of the recoil lug slot in the chassis.
5. Verify clearance on either side of the recoil lug and the front face. The single contact point for the recoil lug is the rear face against the back face of the recoil lug recess as depicted below.

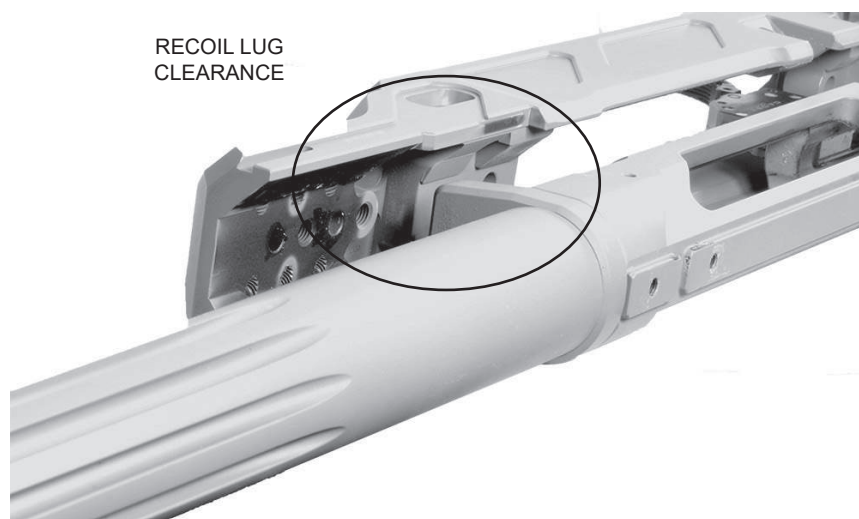

6. Hold the barreled action in place and turn over to check the fit of the trigger mechanism; identify any clearance issues between the trigger, safety catch and the corresponding recess in the chassis, as shown below.



7. After confirming there are no clearance issues with the trigger or safety mechanisms, insert and start the front and rear action/receiver screws. Pay attention to install the Belleville washer in the correct orientation as shown in the green circle above. Do not fully tighten at this time.
8. Once both screws are in place, press the muzzle against a fixed object to ensure the recoil lug is firmly resting against the Chassis lug recess contact point. While holding slight tension, tighten the two action screws. Alternate tightening between both front and rear screws to keep even tension. Continue this process until full torque (65 in-lbs / 7.34 N-m) is reached.

B. Installation of detachable base and magazine sleeve

1. Fit the magazine sleeve into the detachable base.

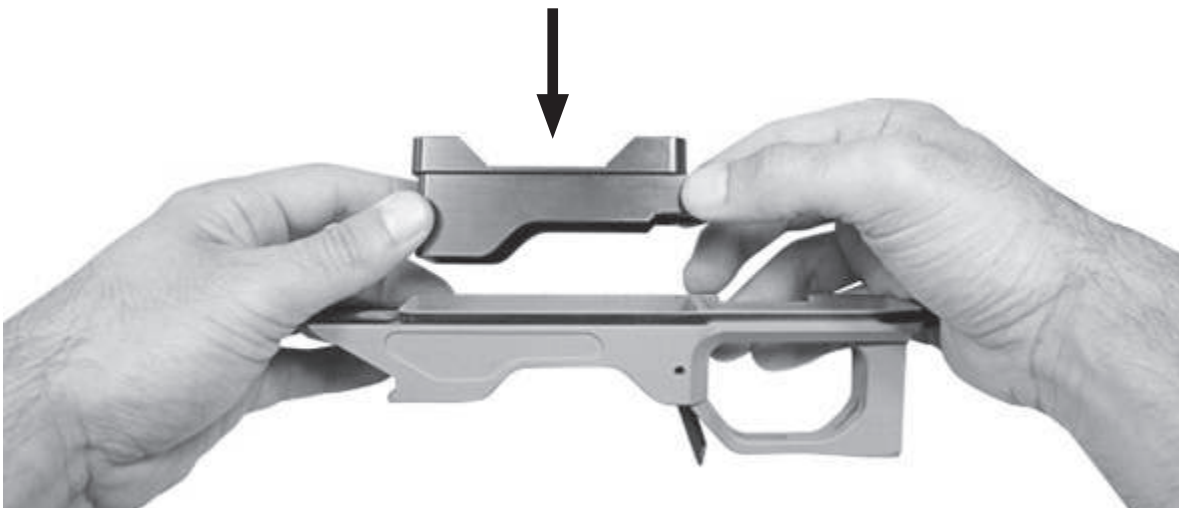

- Fit the detachable Base (item D) onto the bottom flat of the chassis; the front of the base is located by a protrusion that engages into a pocket.

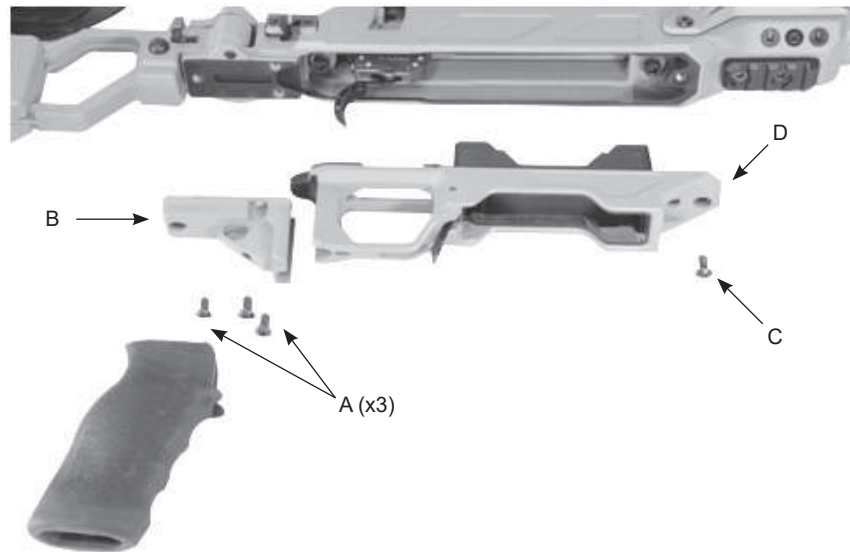

- Install the pistol grip plate (item B) then install and tighten all four button head cap screws (items A and C). Torque screws to 25-30 in-lbs (2.82 N-m - 3.39 N-m).
- Install pistol grip using provided screw (inside grip). Torque this screw to 35 in-lbs (3.95 N-m).
- Check clearance of magazine well with an empty magazine.
- With magazine inserted pull down on the magazine to confirm that the magazine catch functions and retains the magazine in position.
- Insert a dummy/inert cartridge into the magazine. Operate the bolt to confirm proper feeding.

C. Installation of top rail and fore-end tube

- Slide the hand guard tube over the barrel and into the chassis.
- Install the two bottom hand guard tube screws (and the two BHSCS spare screws for the LITE version) but do not fully tighten.
- Install the two (one left and one right) side plates and start but do not fully tighten retaining screws.

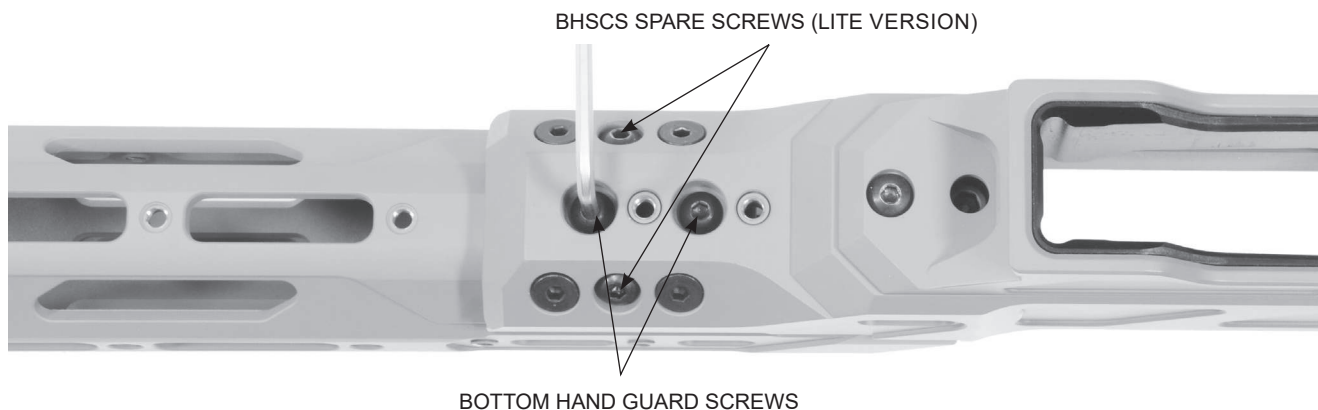

NOTE: for the LITE configuration, the four flat head screws and two bottom cap screws adjacent to the bottom hand guard tube screws are spare screws for attaching top, side, mono or bipod MIL-STD-1913 rail sections.

4. With the hand guard tube loosely installed (screws should not be tightened) the receiver top rail can now be fitted to the action.
5. Remove any filler screws from the top of the action. Install the receiver top rail and ensure proper orientation.
6. Apply pressure on the rail to ensure it is firmly down against the receiver and pressed fully forward to ensure the rail lug is against the inside face of the receiver.
7. Insert and install (start) all aft section top rail mounting screws.
8. Install the front section top rail on the tube. Insert and install (start) all front section top rail mounting screws.
9. Incrementally tighten each screw to the required torque specification (varies due to screw diameter, see Appendix B).
10. After completing the installation of the top rail receiver, return to the hand guard tube base and fully tighten all fasteners in the following order:
 - A) Fully tighten the bottom two hand guard tube screws to 25-30 in-lbs (2.82 N-m - 3.39 N-m) each.
 - B) Fully tighten all six of the side plate screws to 20-25 in-lbs (2.26 N-m - 2.82 N-m).
 - C) For the LITE version, fully tighten the spare BHSCS to 20-25 in-lbs (2.26 N-m - 2.82 N-m).

4. LOADING/UNLOADING OF THE FIREARM

4.1. Loading

1. Point the rifle in a safe direction.
2. Move the safety lever to the “red” position.
3. Raise the bolt handle and pull it all the way to the rear.
4. Insert loaded magazine until it locks into the mag well.
5. Slowly slide the bolt all the way forward until the cartridge is in the chamber.
6. Finish closing the bolt on the cartridge by pushing down the bolt handle.
7. **The rifle is now loaded.**

4.2. Unloading

1. Point the rifle in a safe direction.
2. Move the safety lever to the “red” position.
3. Raise the bolt handle and pull it all the way to the rear. The fired round will come out by the ejection port.
4. Remove the magazine by pushing forward the magazine catch. The magazine will fall down.

5. CLEANING AND MAINTENANCE

WARNING! Verify the chamber and magazine to make sure there are no cartridges in the firearm prior to any cleaning and maintenance on the firearm.

5.1. Suggested cleaning products and equipments

Cadex suggest the following product for the cleaning of your rifle. Other product may be found suitable and it's your responsibility to validate if the cleaning product is compatible with your rifle.

1. High quality coated cleaning rod sized for your bore. This will help prevent damage to your barrel.
2. Cleaning jag and patches sized for your bore.
3. Bore brush made with ether brass or synthetic bristles sized for your bore.
4. High quality bore guides

Cadex recommend the Bore Tec line of cleaning products. Cadex suggest to purchase a carbon cleaner, copper cleaner and gun oil.

5. For carbon removal us the Bore Tec C4 carbon remover
6. For copper removal us the Bore Tec Cu+2 copper remover
7. Use a high quality oil to treat the bore after cleaning.

For the bolt assembly, Cadex recommend the following :

8. A basic CLP (clean lubricate protect) like Lucas CLP product to remove any old lube and grime built up on the bolt.
9. A basic bolt grease like Bore Tech Extreme Grease HD or similar product.
10. Light gun oil or gun oil wipes

For a complete list of compatible product, please visit our website www.cadexdefence.com

5.2. Barrel and Receiver cleaning

Cadex recommend the use of a cleaning cradle to secure your rifle. If not, make sure to have the rifle angle down toward the muzzle to ensure no cleaning product come back into the chamber and action. Make sure you are in a well-ventilated room, some cleaning chemicals can have a very strong odor.

1. Make sure the firearm is unloaded and remove the bolt and magazine.
2. Place the bore guide into the action and press forward lightly to make a good seal at the chamber.
3. Run a patch soaked in Carbon cleaner through the bore from the action. At the muzzle end remove the jag and inspect the patch. Depending on cleaning schedule patch will likely be black with some blue. Repeat this for a total of 3 patches. Never reuse a soaked patch.
4. Next, run a bore brush up and down the bore 10 time to loosen any Carbon. Then repeat step 3 and 4 till patches come out with almost no black.
5. Now move onto copper removal. Run a patch soaked in Copper cleaner through the bore. At the muzzle end remove the jag and inspect the patch. Depending on cleaning schedule patch will likely be blue. Repeat this for a total of 3 patches. Never reuse a soaked patch.
6. Next, run a bore brush up and down the bore 10 time to loosen any copper. Then repeat step 5 and 6 till patches come out with almost no blue.

7. Cadex recommend running a couple dry patches down the bore to remove any chemicals then a patch lightly soaked in gun oil to protect the bore especially if you plan to store the firearm for some time. Remember to always run a dry patch through the rifle before firing again to remove any residual oil.

5.3. Bolt cleaning

1. Remove the bolt from the action.
2. Take a paper towel or Rag and dampen with CLP. Wipe down the bolt body and lugs removing built up grease and dirt.
3. Then, remove the firing pin assembly following the instructions in the manual. Wipe down all internal part with the CLP.
4. Put a light coating of gun oil on the internal parts and re-install the firing pin assembly.
5. Place a small dab of grease behind each calking lug and small amount on calking ramp.
6. Apply a light coat of gun oil to your bolt body.
7. Reinstall the bolt into the action and cycle to evenly distribute grease and oil.
8. Activate the ejector and the extractor and ensure they move freely without sticking. **WARNING!** If the ejector or the extractor sticks, see a gunsmith for service.
9. Verify there are no cartridges in the rifle, close the bolt and pull the trigger. The firing pin must fall. Repeat at least 5 times. Use of snap caps is strongly recommended.

WARNING! If the firing pin does not fall or do not remain cocked when the bolt is closed smartly, then your rifle is NOT in a safe operating condition and it must NOT be used until you have had it inspected by a gunsmith.

10. Repeat step 9 with the safety lever to the “green” position. The firing pin must NOT fall and the bolt shall be locked in place. Repeat at least 5 times.

WARNING! If the firing pin falls or the bolt is not locked, then your rifle is NOT in a safe operating condition and it must NOT be used until you have had it inspected by a gunsmith.

5.4. Trigger cleaning

1. Remove the bolt assembly and turn the rifle upside down.
2. Following the instruction in the manual, remove the detachable base to access the trigger area.
3. Clean the trigger assembly with a high quality rifle safe degreaser. Do not leave any degreaser on coated surface any longer than necessary. Attention! Always use a degreaser compatible with guns and triggers (do not use industrial degreaser like brake cleaner or petroleum - based solvent like gas lighter).
4. Apply a light coat of gun oil to your trigger moving parts, then wipe all excess lubricant with a clean rag.
5. Pull the trigger backward and release. Verify that it return completely to the forward position each time. Repeat at least 5 times.

WARNING! If the trigger does not fully return to the forward position each time it is released, then your rifle is NOT in a safe operating condition and it must NOT be used until you have had it inspected by a gunsmith.

6. Reinstall the bolt into the action and make sure there are no cartridges in the rifle. Then, close the bolt and pull the trigger. The firing pin must fall. Repeat at least 5 times. Attention! Use of snap caps is strongly recommended.

WARNING! If the firing pin does not fall or doesn't remain cocked when the bolt is closed smartly, then your rifle is NOT in a safe operating condition and it must NOT be used until you have had it inspected by a gunsmith.

- Repeat step 6 with the safety lever to the “green” position. The firing pin must NOT fall and the bolt shall be locked in place. Repeat at least 5 times.

WARNING! If the firing pin fall or the bolt is not locked, then your rifle is NOT in a safe operating condition and it must NOT be used until you have had it inspected by a gunsmith.

5.5. Chassis cleaning and maintenance

- When tightening fasteners do not over tighten. Where a torque is specified, employ an accurate in-lbs torque wrench. Use correct fitting tools to loosen or tighten fasteners.
- When operating the controls of the stock, do not use excessive force.
- To clean the chassis, use a soft brush to remove accumulated sand, mud and debris. Wipe down surfaces using soft rags. Do not use harsh chemicals or any abrasive materials to clean the chassis.
- Small amounts of a light lubricant can be applied to the stock hinge and lock (LITE configuration only).

5.6. Threadlocker application procedure

Your firearm came with a threadlocker liquid that need to be applied on screws prior assembly and torque. The threadlocker will prevent screws loosening from vibration and shock and provide screws lubricity during torque procedure.

- Before applying threadlocker, verify that both thread on screws and hole are free from rust, dirt or debris, oil, and grease.
- For through holes, apply threadlocker directly on screws (fig 1).

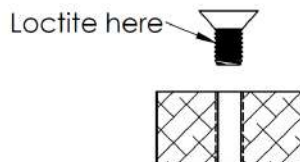

Fig.1 Through Hole

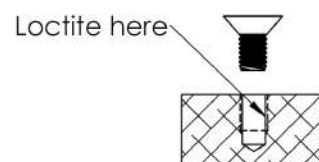

Fig.2 Blind Hole

- For blind holes, apply threadlocker on thread hole (fig 2).
- Once threadlocker is applied, tighten all screws by hand and then torque them to the appropriate torque.
- We recommend letting the threadlocker cure for a 24h period before using your firearm.

6. TECHNICAL AND WARRANTY SUPPORT

For technical and warranty support, the point of contact is Cadex Defence. Contact information:

CADEX INC. 755 avenue Montrichard, Saint-Jean-sur-Richelieu, Québec, Canada J2X 5K8
E-mail : sales@cadexdefence.com Website: www.cadexdefence.com Tel: 450-348-6774

To order parts, please have the following before contacting us:

- Firearm model and serial number
- Firearm and chassis color
- Your complete mailing address
- Part description, item number and quantity (they can be found on Appendix A)

This document contains information that is proprietary to Cadex Inc. Neither this document nor the information contained herein shall be used, duplicated or communicated by any means to any third party, in whole or in part, except with the prior written consent of Cadex Inc. This restrictive legend shall not be altered or obliterated from this document.



Limited Lifetime Warranty

At Cadex Defence we take a great sense of pride in the products that we design and produce as well as our customer service. If you are experiencing any problems, we appreciate your honesty with the situation and we will do what is right to help you as we really care for our customers.

We warrant products manufactured by Cadex Inc. to be free of defects in material or workmanship/manufacturing for **one year** following the initial owner's purchase. Cadex Defence reserves the right to cover under warranty, at its own discretion, its products for the **lifetime** of the product if we feel that it didn't meet our high standards of performance. Cadex reserves the right to use its discretion to warranty its products in special scenarios that have or may present themselves that are not noted in this document.

Cosmetic wear and normal wear items including but not limited to the barrel, extractors, ejectors, and springs are not covered by the warranty and it is the responsibility of the owner to assure the weapon is properly maintained.

Your Cadex Defence product was manufactured to perform properly with the original parts as designed. Altering or modifying parts is dangerous and will void the warranty. It is your responsibility to make sure any parts you install are made for this firearm, installed correctly, and that neither the originals nor the replacement parts are altered or changed. Firearms are complex precision tools with many parts that must operate correctly with other parts in order to maintain proper and safe operation. Putting your firearm together improperly or with incorrect or modified parts can result in a damaged firearm, serious personal injury, or death to you and/or others through malfunction. Always have a qualified armorer or gunsmith work on your Cadex Defence system or other firearms.

Please have the following information ready. You can contact us via email or toll free at the contact information listed below.

- Product Model
- Serial Number
- Date of Purchase
- Point of Purchase

CADEX INC.

755 Avenue Montrichard, St-Jean-sur-Richelieu, Quebec, Canada, J2X 5K8

customerservice@cadexinc.com

Office: 450-348-6774 (CANADA) • 802-466-4003 (USA)

Toll free: 1-888-348-6774

A message from the owner

For Cadex, customer satisfaction is very important.

If you experience a problem with one of our dealers or distributors don't wait for the situation to get worse before bringing it to our attention. We firmly believe that with good communication and a little goodwill from both sides we will be able to find a solution to your problem.

Please contact us as soon as possible if you ever encounter any issues with one of our products.

- Serge Dextraze, Cadex CEO

7.2. Chassis spare parts - LITE configuration (1/3)

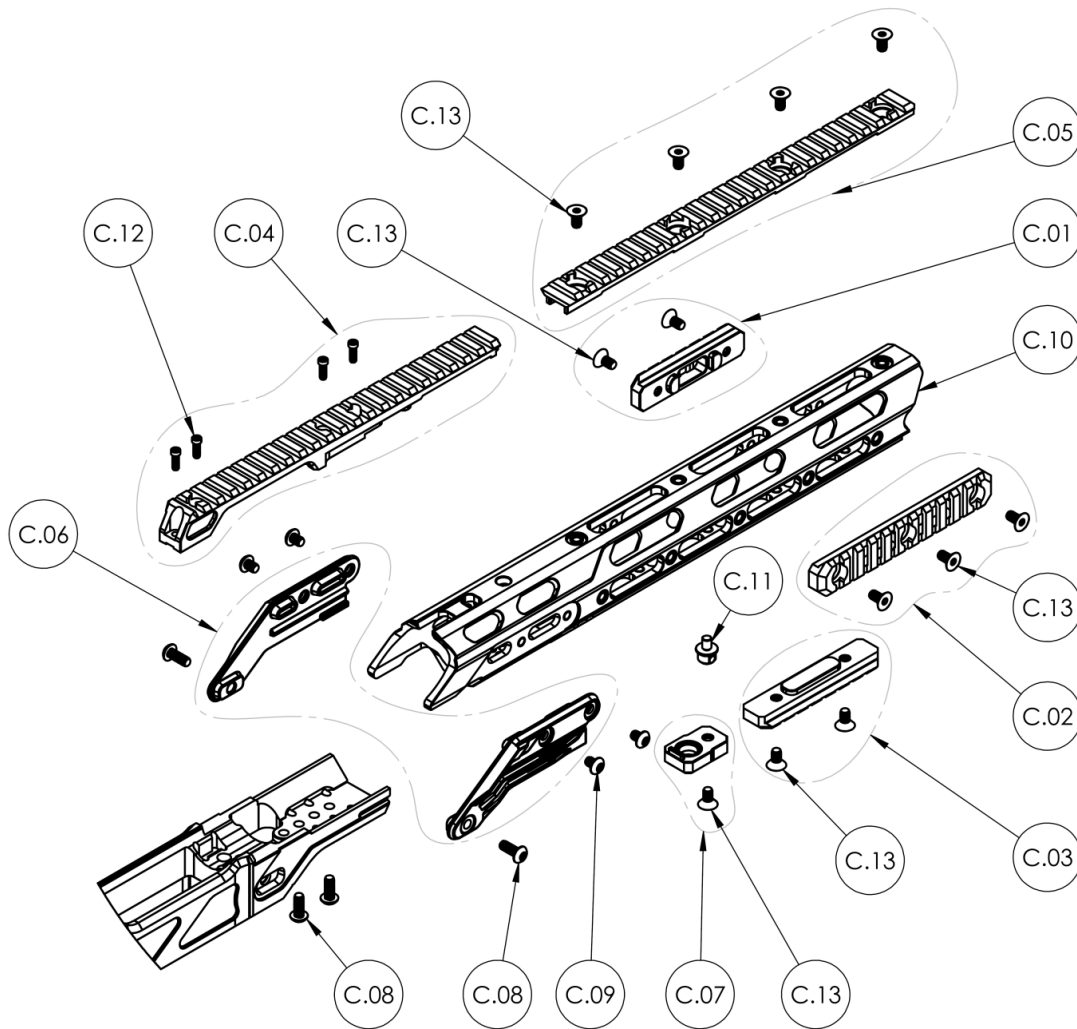

ITEM	DESCRIPTION	QTY
C.01	3" SHORT MODULAR RAIL KIT	1
C.02	5" SHORT MODULAR RAIL KIT	1
C.03	ALUMINUM BIPOD RAIL KIT	1
C.04	TOP RAIL KIT	1
C.05	FORE-END TOP RAIL KIT	1
C.06	SIDE PLATE KIT	1
C.07	SLING MOUNT KIT	1
C.08	BHSCS 10-32 X 1/2", SS	4
C.09	BHSCS 10-32 X 1/4", SS	4
C.10	FORE-END TUBE ASSEMBLY	1
C.11	BIPOD STUD (WASHER INCLUDED)	1
C.12	TOP RAIL SCREWS	4
C.13	FHSCS 10-32 X 3/8"	12

7. APPENDIX A - SPARE PARTS

7.1. Firearm spare parts

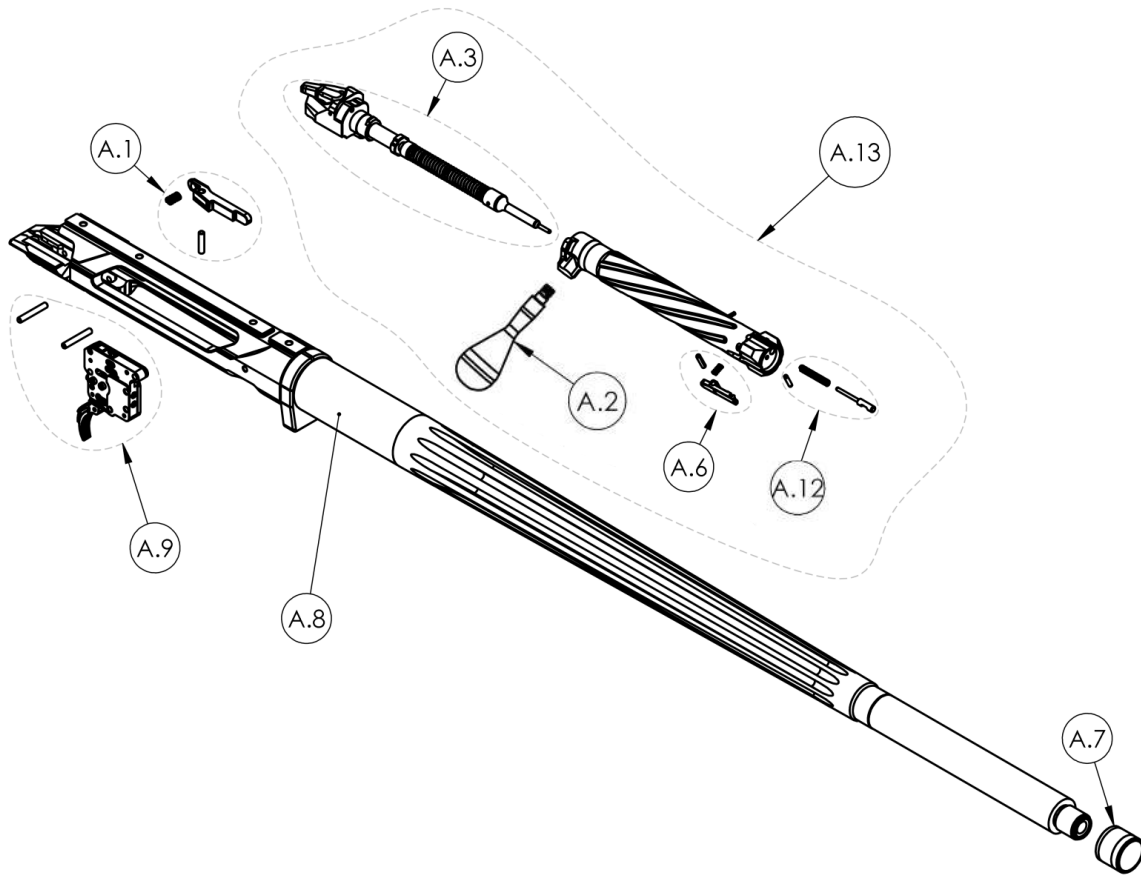

ITEM	DESCRIPTION	QTY
A.1	BOLT STOPPER KIT	1
A.2-a	OVERSIZED CROSS HATCH BOLT KNOB (NOT SHOWN)	-
A.2-d	ROUNDED KNOB	1
A.3	FIRING PIN ASSEMBLY	1
A.6	EXTRACTOR KIT	1
A.7	BARREL THREAD CAP	1
A.8	BARREL ASSEMBLY (PLEASE SPECIFY MODEL, CALIBER AND BARREL LENGTH WHEN ORDERING)	1
A.9	DOUBLE STAGE TRIGGER ASSEMBLY	1
A.12	EJECTOR KIT	1
A.13	BOLT ASSEMBLY (PLEASE SPECIFY MODEL AND CALIBER WHEN ORDERING)	1

7.2. Chassis spare parts - LITE configuration (2/3)

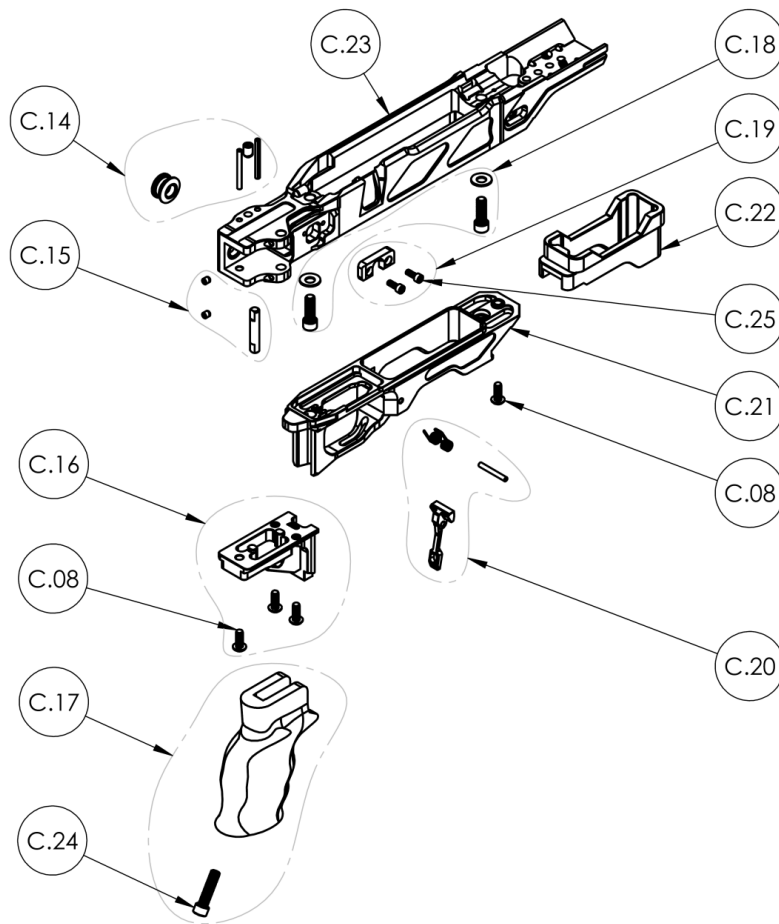

ITEM	DESCRIPTION	QTY
C.08	BHSCS 10-32 X 1/2", SS	4
C.14	ADJUSTABLE LOCKING MECHANISM KIT	1
C.15	HINGE PIN KIT	1
C.16	GRIP HOLDER KIT	1
C.17	TACTICAL PISTOL GRIP KIT	1
C.18	ACTION SCREW KIT (2 SCREWS AND 2 WASHER)	1
C.19	SIDE LOCKING CATCH KIT	1
C.20	MAGAZINE CATCH KIT	1
C.21	DETACHABLE BASE (WITH MAGAZINE CATCH)	1
C.22	MAGAZINE SLEEVE	1
C.23	LOWER RECEIVER	1
C.24	SHCS 1/4-28 X 1"	1
C.25	SHCS 6-40 X 3/8", SS	2

7.2. Chassis spare parts - LITE configuration (3/3)

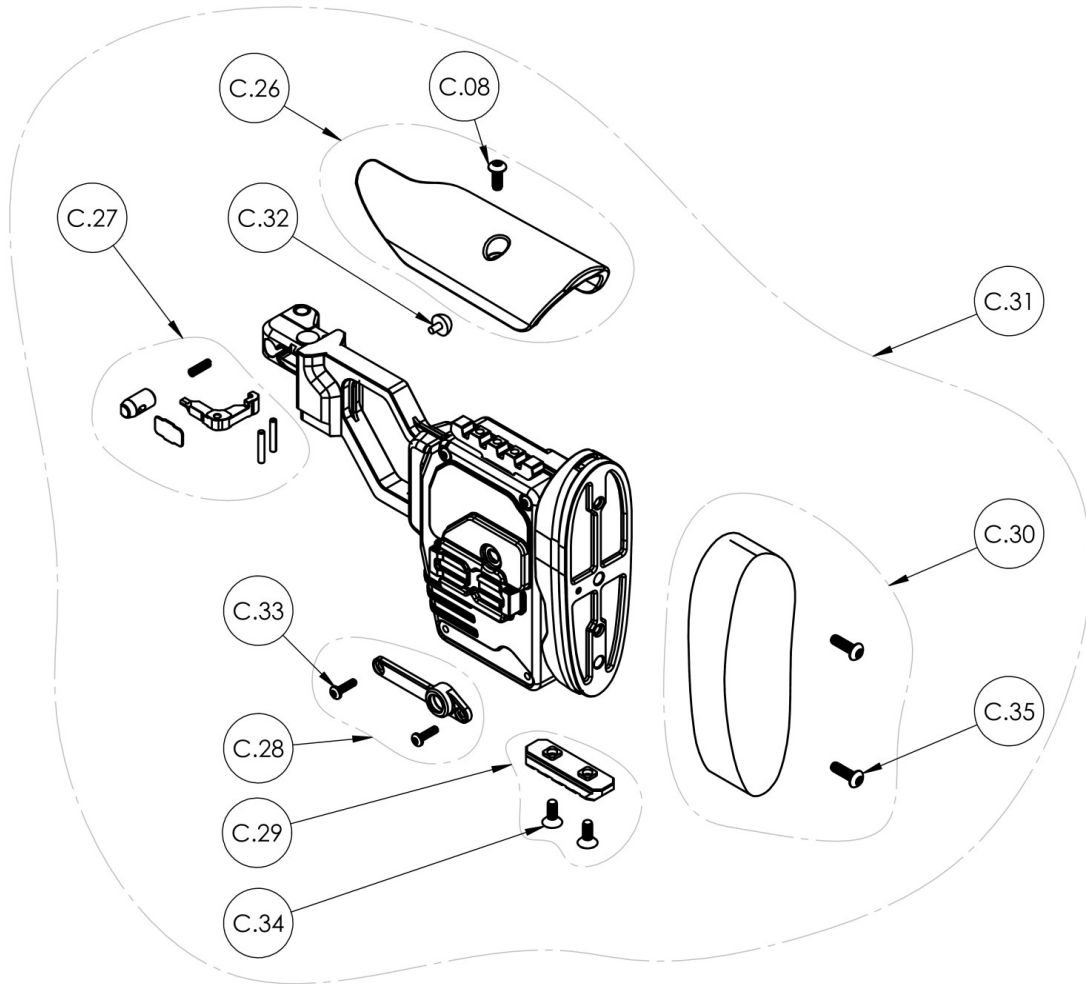

ITEM	DESCRIPTION	QTY
C.08	BHSCS 10-32 X 1/2", SS	1
C.26	CHEEK PIECE KIT	1
C.27	FOLDING LOCKING MECHANISM KIT	1
C.28	BUTT STOCK SLING ADAPTER	1
C.29	BUTT STOCK RAIL	1
C.30	BUTT PAD KIT	1
C.31	COMPLETE BUTT STOCK ASSEMBLY	1
C.32	RUBBER BUMPER	1
C.33	TORX BHCS 6-32 X 1/2", SS	2
C.34	FHSCS 10-32 X 1/2", SS	2
C.35	BHSCS 10-32 X 5/8", SS	2

7.3. Chassis spare parts - TAC configuration (1/2)

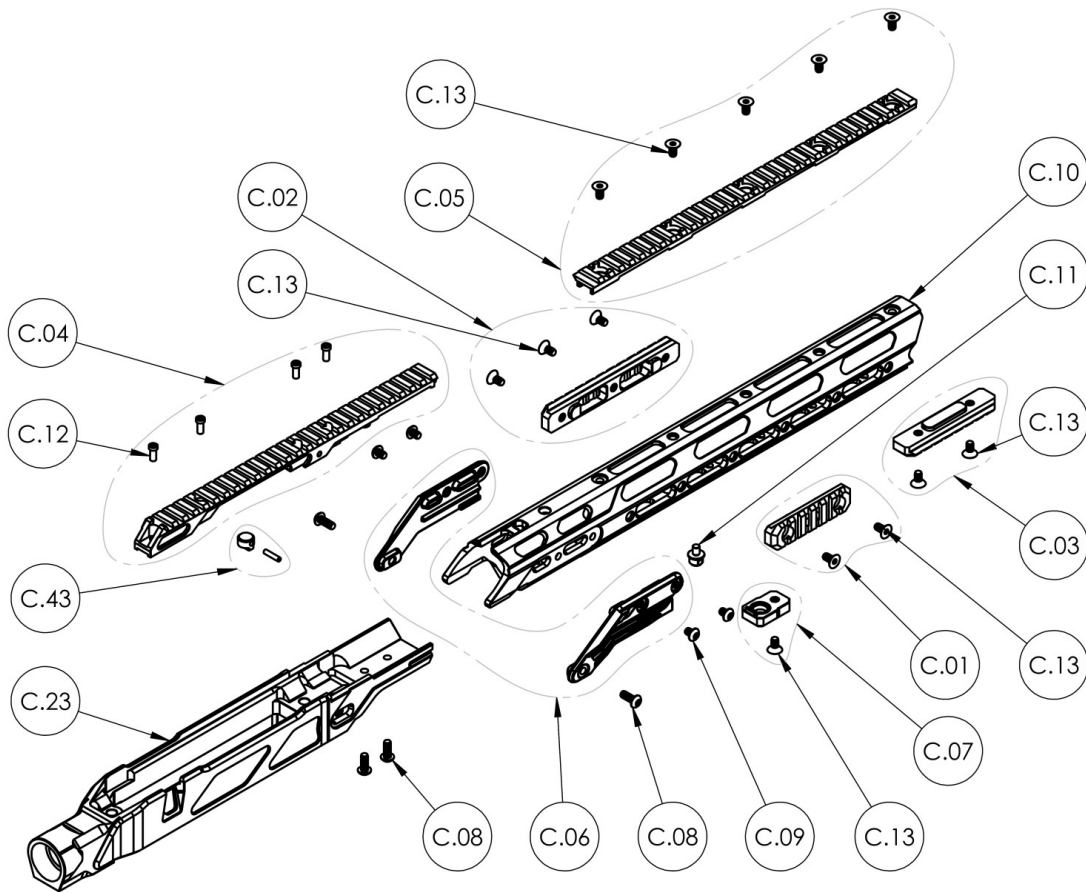

ITEM	DESCRIPTION	QTY
C.01	3" SHORT MODULAR RAIL KIT	1
C.02	5" SHORT MODULAR RAIL KIT	1
C.03	ALUMINUM BIPOD RAIL KIT	1
C.04	TOP RAIL KIT	1
C.05	FORE-END TOP RAIL KIT	1
C.06	SIDE PLATE KIT	1
C.07	SLING MOUNT KIT	1
C.08	BHSCS 10-32 X 1/2", SS	4
C.09	BHSCS 10-32 X 1/4", SS	4
C.10	FORE-END TUBE ASSEMBLY	1
C.11	BIPOD STUD (WASHER INCLUDED)	1
C.12	TOP RAIL SCREWS	4
C.13	FHSCS 10-32 X 3/8"	13
C.23	LOWER RECEIVER	1
C.43	TOP RAIL RECOIL LUG	1

7.3. Chassis spare parts - TAC configuration (2/2)

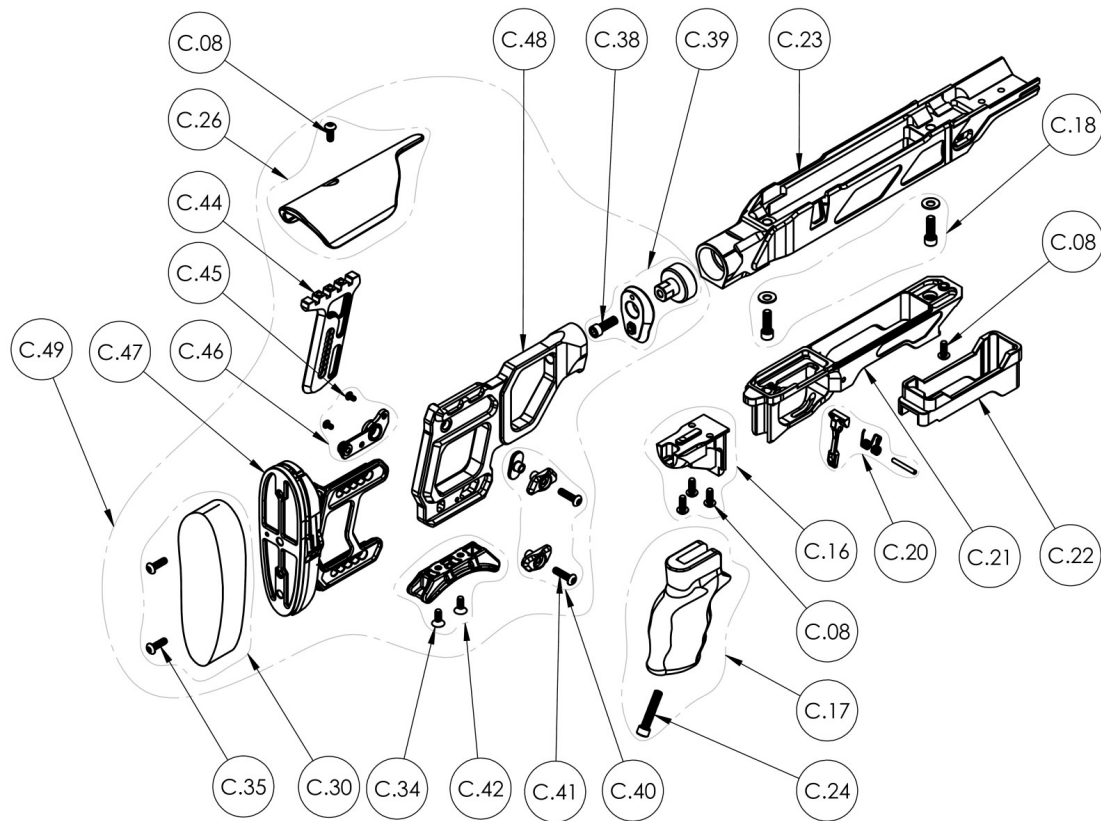

ITEM	DESCRIPTION	QTY
C.08	BHSCS 10-32 X 1/2, SS	5
C.16	GRIP HOLDER KIT	1
C.17	TACTICAL PISTOL GRIP KIT	1
C.18	ACTION SCREW KIT (2 SCREWS AND 2 WASHER)	1
C.20	MAGAZINE CATCH KIT	1
C.21	DETACHABLE BASE (WITH MAGAZINE CATCH)	1
C.22	MAGAZINE SLEEVE	1
C.23	LOWER RECEIVER	1
C.24	SHCS 1/4-28 X 1"	1
C.26	CHEEK PIECE KIT	1
C.30	BUTT PAD KIT	1
C.34	FHSCS 10-32 X 1/2", SS	2
C.35	BHSCS 10-32 X 5/8", SS	2
C.38	SHCS 1/4-28 X 1-1/4"	1
C.39	BUTT STOCK INTERFACE KIT	1
C.40	LOCKING PARTS KIT	1
C.41	BHSCS 10-32 X 3/4"	2
C.42	BEAN BAG RIDER KIT	1
C.44	CHEEK PIECE RAIL	1
C.45	BHSCS 6-32 X 1/4"	2
C.46	FLUSH CUP SLING ADAPTER KIT	1
C.47	LOP ADJUSTMENT BRACKET	1
C.48	SKELETON BUTT MAIN FRAME	1
C.49	SKELETON BUTT COMPLETE ASSEMBLY	1

8. APPENDIX B - RECOMMENDED TORQUE SETTING

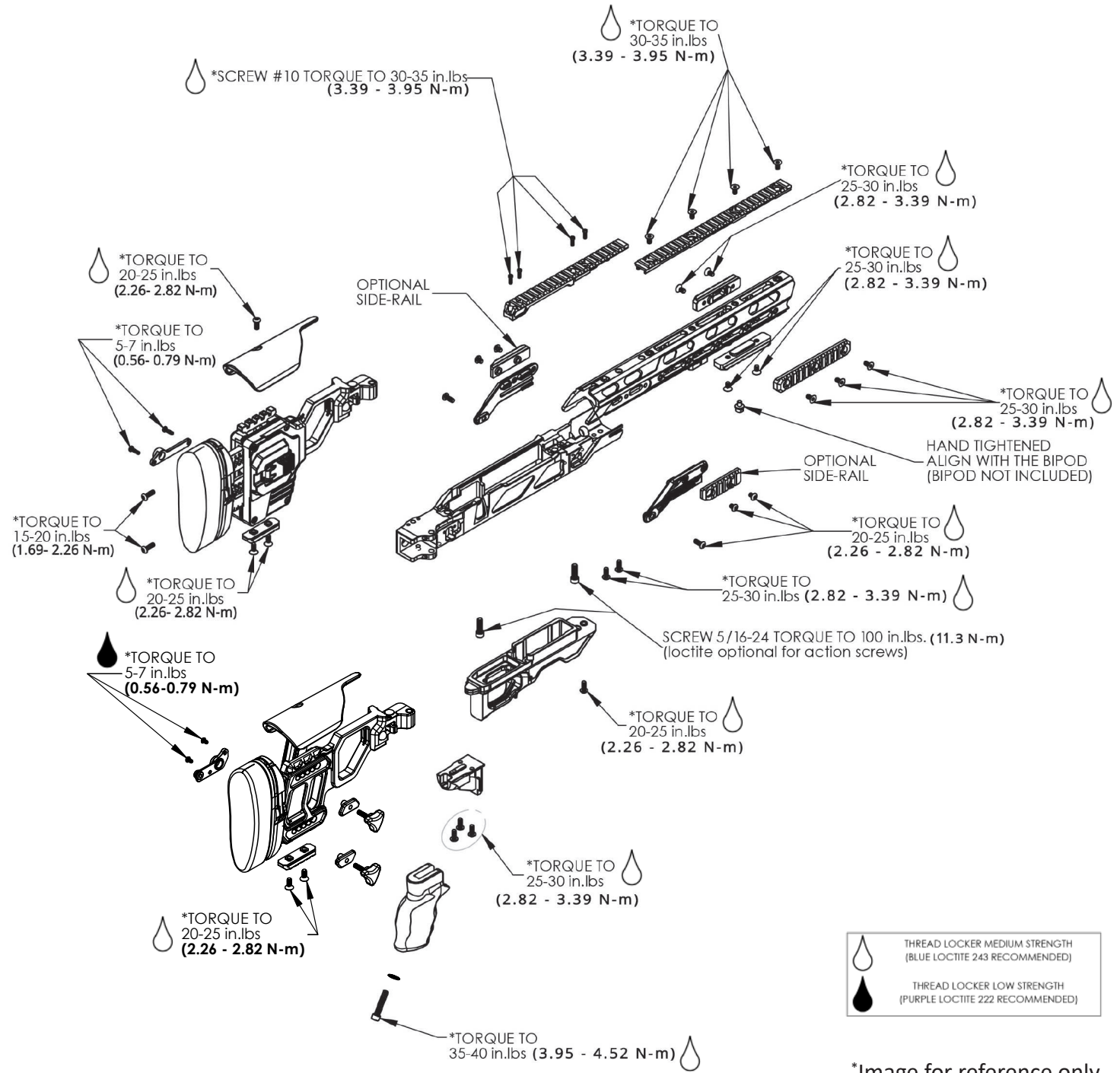

*Image for reference only

WARNING! Regardless of shipping method, Cadex highly recommends checking each preset screws torque preventively.

If your order shipped by plane, and as such, withstood high amounts of vibrations, you MUST verify each preset screws for the right torque before using the weapon by referring to the figure above.

This document contains information that is proprietary to Cadex Inc. Neither this document nor the information contained herein shall be used, duplicated or communicated by any means to any third party, in whole or in part, except with the prior written consent of Cadex Inc. This restrictive legend shall not be altered or obliterated from this document.





CADEX INC.

HEAD OFFICE

755 ave. Montrichard,
Saint-Jean-sur-Richelieu, QC
Canada, J2X 5K8

Tel: 450-348-6774

Toll free: 1-888-348-6774

Fax: 450-348-7157



WWW.CADDEXDEFENCE.COM