

## CDX-300/33 - BOTTOM METAL

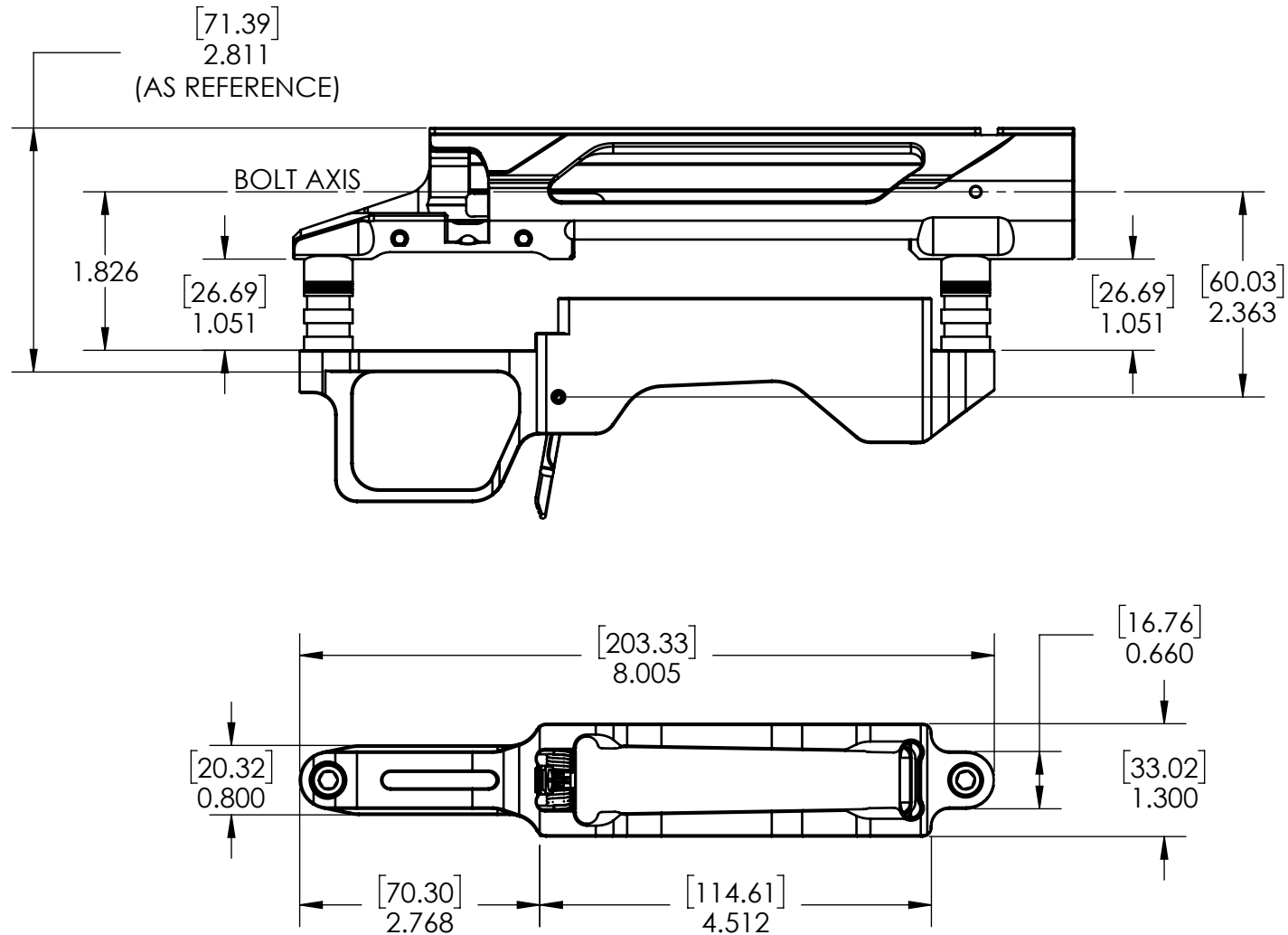

ALL DIMENSION ARE **INCHES**  
DIMENSION IN [ ] ARE IN **mm**

# CDX-300/33 - BOTTOM METAL

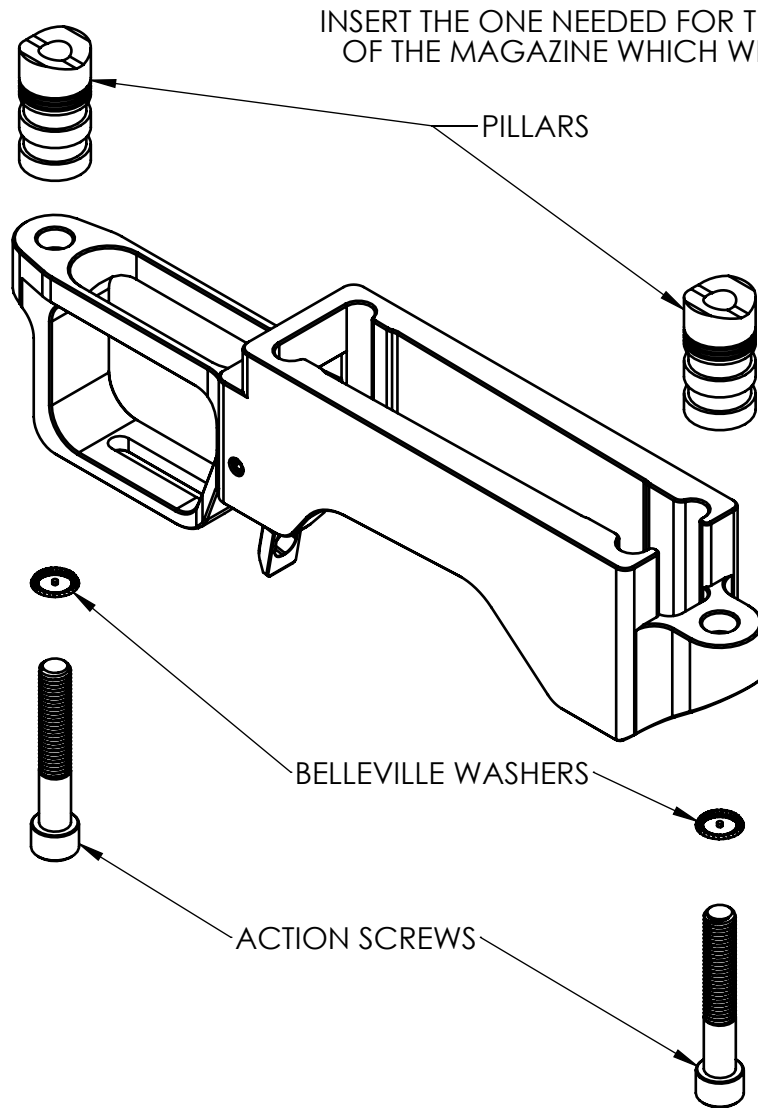

INSERT THE ONE NEEDED FOR THE LENGTH OF THE MAGAZINE WHICH WILL BE USE

PILLARS

BELLEVILLE WASHERS

ACTION SCREWS

COMPATIBLE WITH **AICS** MAGAZINES

- SSSF 3.715"
- SSSF 3.775"
- SSSF 3.850" CIP

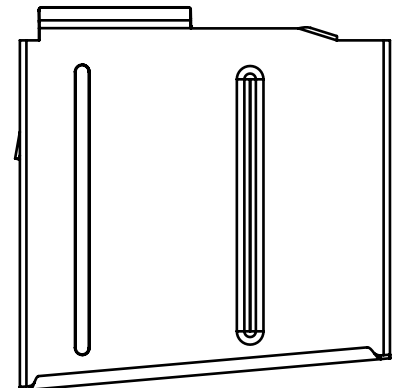

## CADEX BOTTOM METAL INSTALLATION PROCEDURE

- 1- REMOVE THE BARRELED ACTION ASSEMBLY FROM THE ORIGINAL STOCK.
- 2- REFER TO THE DRAWING FOR THE DIMENSIONS NEEDED FOR THE MACHINING OF THE STOCK.
- 3- ONCE THE MACHINING OF THE STOCK IS DONE, INSERT THE BOTTOM METAL, THE BARRELED ACTION ASSEMBLY AND THE PILLARS IN THEIR POSITION. USE THE WASHERS AS TOLD ON THE DRAWINGS AT THE PROPER POSITION (IF THEY ARE NEEDED). SECURE THE COMPONENTS IN PLACE BY SCREWING THE HARDWARE INCLUDED IN THE PACKAGE. THE SCREWS MUST BE TORQUED TO THE SPECS RECOMMENDED BY THE BARRELED ACTION MANUFACTURER.

